

Ice-Tek®



MADE IN ITALY

PRODUTTORI DI GHIACCIO
CUBETTO PIENO
FULL CUBES ICE MAKERS

PRODUTTORI DI GHIACCIO
GRANULARE
GRANULAR ICE MAKERS

PRODUTTORI DI GHIACCIO
IN SCAGLIE
FLAKE/SCALE ICE MAKERS



CATALOGO CATALOGUE 2022/3



BY



Pub. 09/22



Rispondiamo a tutte le vostre esigenze.

Ice-Tek, brand di proprietà di Minerva Omega Group s.r.l., vuol dire innovazione nel settore dei produttori di ghiaccio. Eredita un'esperienza tecnica industriale di grande tradizione particolarmente orientata alla qualità, all'affidabilità delle macchine proposte, unitamente ad un servizio di assistenza post vendita.

Tecnologia e performance produttive, le macchine di questa linea soddisfano ogni esigenza artigianale o industriale senza richiedere particolari interventi installativi e con una forte attenzione verso la semplicità d'uso.

Solutions to your needs.

Ice-Tek, brand of Minerva Omega Group s.r.l., means innovation in the ice makers manufacturing. The tradition focused to quality guarantees reliable equipments, together with professional after sale service.

Performances and technology, machines meet both industrial and retail requirements easy to install, users friendly.

Une solution pour tous cas.

Ice-Tek, une marque détenue par Minerva Omega Group s.r.l., signifie l'innovation dans les machines à glaçons. Hérite une technique industrielle de grande tradition particulièrement orienté vers la qualité, la fiabilité des machines proposé, avec un service après-vente.

Technologie et performances productives, nos machines sont la réponse à toutes exigences soit industrielles soit artisanales. Installation simple et "users friendly".

Respondemos a vuestras necesidades.

Ice-Tek, una marca de Minerva Omega Group s.r.l., significa innovación en el sector de los fabricantes de hielo. Materializa una experiencia técnica industrial de gran tradición y particularmente orientada a la calidad y confiabilidad de las máquinas presentadas junto a una óptima asistencia post-venta.

Tecnología y performance productiva, las máquinas de nuestra línea satisfacen cada una de las exigencias artesanales o industriales sin especiales/grandes tareas de instalación y con una fuerte tendencia hacia la simplicidad en el uso de las mismas.

I dati del presente catalogo non sono impegnativi e potranno subire variazioni senza preavviso.

Specifications and other features are subject to change without notice.

Les info ici contenues ne sont pas obligants et peuvent être modifiées sans préavis.

Especificaciones y otras características sujetas a cambios sin previo aviso.





NEMOSY (NEXUS MONITORING SYSTEM)

Il sistema **NeMoSy[®] (Nexus Monitoring System)** permette di acquisire, trasmettere, analizzare e consultare dati.

I fabbricanti di ghiaccio Ice-Teck[®] possono prevedere su richiesta tale tecnologia.

Gli obiettivi

L'acquisizione dei dati di telemetria insieme all'archiviazione dei documenti, permette ai diversi stakeholder (Energy Manager, Plant Manager, Technical Manager, End-User...) di:

- Ridurre drasticamente i costi per la **gestione della manutenzione**.
- Mantenere quando realmente necessario, **manutenzione predittiva**.
- Archiviare i **rapporti**, e i **costi sostenuti, di Manutenzione**.
- **Risolvere un fermo macchina** a distanza.
- Controllare con precisione i **consumi energetici** di ogni singola macchina.
- **Geo-localizzare le macchine**.
- **Archiviare documenti** (Dich. CE, Manuali, Depliant, Liste ricambi...).
- Ricevere **allarmi tramite email o sms**, al verificarsi di determinate condizioni.

I vantaggi di NeMoSy[®]

- Basso costo.
- Prolungamento della vita dei macchinari.
- Gestione macchine centralizzata.
- Accesso ai dati differenziato in base alle credenziali di accesso.
- Sistema Plug&Play: Nessuna operazione di configurazione richiesta.

Dati Rilevati negli Ice-Makers

Corrente Istantanea, Potenza Assorbita, Temp. Acqua, Temp. Ambiente, Produzione Ghiaccio, Ore, ecc.

NeMoSy[®] system (Nexus Monitoring System) allows to detect, transmit, analyse and check data.

Ice-Teck[®] ice makers can be equipped on request with this system.

Objectives:

Telemetry data acquisition, along with documents archiving, allows the different stakeholders (Energy manager, Plant manager, technical manager, End Users...) to:

- *drastically reduce the **maintenance costs***
- *proceed with **maintenance works** only when It's necessary (predictive maintenance)*
- *retain a **record of maintenance costs and reports***
- ***check and solve machine** downtimes remotely*
- *monitor accurately the **energy consumptions** of every single machine*
- ***geolocate the machines***
- ***save digitally and archive documents** (CE certifications, Instruction manuals, information leaflets, list of replacement parts...)*
- *receive **alert notifications through e-mail or SMS**, on the upon the occurrence of certain conditions.*

NeMoSy[®] Advantages:

- *Low priced*
- *Longer machine life*
- *Centralised management of machines*
- *Differentiated data access depending on log-in information.*
- *Plug&Play System. No configuration needed.*

Data detected by NeMoSy[®] on Ice-Makers:

instant current, absorbed current, water temperature, air temperature, Ice production, hours in use, hours worked exc..



PH-METRO NEMOSY

Il sistema pH-metro a tutela della qualità dell'acqua o del ghiaccio utilizzato nel comparto alimentare.

Minerva Omega Group introduce un nuovo sistema per monitorare e valutare in modo attivo la qualità dell'acqua usata nel settore alimentare attraverso un'analisi costante, 24 ore su 24. La trasmissione dati avviene attraverso il gateway NeMoSy (dispositivo connesso ad internet, che permette l'invio dei dati alla piattaforma web, tramite connessione sicura crittografata).

In estrema pratica si può parlare di un piccolo laboratorio di analisi indipendente che può essere collegato ad una singola macchina, come ad esempio un fabbricatore di ghiaccio, ad una serie di macchine collegate tra loro, o ad un ingresso di rete idraulica e che trasmette il valore di pH per determinare il grado di aggressività dell'acqua che può variare i suoi parametri diventando più acida e poco mineralizzata, o più alcalina, dura e ricca di calcare.

Il pH-metro NeMoSy

Utilizzato all'interno del sistema NeMoSy, il pH-metro è la soluzione tecnica ideale per monitorare in modo attivo e continuativo la variazione dei valori di pH in un processo produttivo. Ad esempio è possibile verificare l'efficienza di un impianto di addolcimento dell'acqua.

Il pH-metro, costituito da una sonda ed una centralina o trasmettitore, agisce come un controllore attivo perché monitora e registra costantemente sulla piattaforma NeMoSy i valori del pH ed invia un allarme per mail o SMS al controllo centralizzato nel caso rilevi valori fuori standard.

I vantaggi del pH-metro

- Costo modesto
- Monitoraggio 24 ore su 24
- Gestione centralizzata
- Sistema Plug&Play: nessuna operazione di configurazione richiesta
- Contribuisce alla diminuzione dei costi di manutenzione ed al prolungamento della durata delle macchine

Perché la qualità dell'acqua è importante

Che si parli di acqua di processo, cioè l'acqua potabile necessaria alla produzione, o di acqua destinata alla fabbricazione di ghiaccio ad uso alimentare o conservativo del cibo, l'importanza dei valori definiti dall'Organizzazione Mondiale della Sanità è una questione imprescindibile per non uscire dalla legislazione in materia secondo i principi del sistema HACCP.

Potere incrostante e corrosivo monitorato dal pH.

A parte i valori stabiliti e ammessi dalla legge, che stabiliscono un range del pH tra il 6,5 - 8,5, non si devono sottovalutare i problemi e i danni provocati da un'eccessiva durezza dell'acqua che possono compromettere i macchinari per la produzione con un notevole aumento dei costi di gestione e di manutenzione. In tal senso il sistema pH-metro NeMoSy si può considerare uno strumento indispensabile per una moderna gestione centralizzata di una catena produttiva, come ad esempio un'industria ittica, o dei punti vendita della GDO.

Per prezzi e ulteriori informazioni, rivolgersi al nostro Ufficio Commerciale.

PH-meter system safeguards water and ice quality in the food sector

Minerva Omega Group introduces a new system for monitoring and assessing water quality in the food sector through constant, 24-hour analysis. Data is sent through a NeMoSy gateway (connected to the internet, enabling data to be sent to the web platform on a secure encrypted connection).

Put simply, it is a little standalone analysis laboratory that can be connected to an individual machine, such as an ice maker, a series of connected machines, or a piping inlet, which transmits the pH value to determine whether the water corrosivity is more acid and less mineralised or more alkaline, harder and richer in calcium.

NeMoSy pH-meter

Used within the NeMoSy system, the pH-meter is the ideal technical solution for actively and continuously monitoring changes in pH in a production process. For example, it can check the efficiency of a water softening plant.

The pH-meter, made up of a probe and a control unit or transmitter, acts as an active controller because it constantly monitors and records pH values on the NeMoSy platform and sends an alarm by e-mail or text message to the centralised control if it detects non-standard values.

Advantages of the pH-meter

- Moderate cost
- 24-hour monitoring
- Centralised management
- Plug&Play system: no set-up required
- Helps reduce maintenance costs and prolong machine lifespan

Why water quality is important

Whether analysing process water, i.e. the drinking water required for production, or ice-making water for food use or storage, the values set by the World Health Organization must be complied with to stay within legal HACCP system guidelines.

Scale-forming and corrosive power monitored by pH-meter

Aside from the established, legal values, which set a pH range between 6.5 and 8.5, the problems and damage caused by excessive water hardness are not to be underestimated. Production machinery can be compromised, resulting in considerably higher running and maintenance costs. As such, the NeMoSy pH-meter system can be considered a vital tool for managing a modern centralised production chain, such as a fishery, or large-scale retail outlets.

For prices and further information, please contact our Export department.

INTRODUZIONE - INTRODUCTION	
INTRODUCTION - INTRODUCCIÓN	6



PRODUTTORI GHIACCIO CUBETTO / CUBES ICE MAKERS
MACHINE À GLACON / FABRICADORES DE HIELO EN CUBITO

Presentazione prodotto CIM/CIM product presentation/Présentation du produit CIM/Presentación del producto CIM	10
CIM 20/6 - CIM 30/10 - CIM 45/15	11
CIM 50/25 - CIM 85/40 - CIM 90/60L - CIM 100/60	12
CIM 140L - CIM 165/75 - CIM 165 - CIM 280L - CIM 300	13



PRODUTTORI GHIACCIO GRANULARE / GRANULAR ICE MAKERS
MACHINES À GLACE EN GRAINS / MÁQUINAS DE HIELO GRANULAR

Presentazione prodotto GIM-N/GIM-N product presentation/Présentation du produit GIM-N/Presentación del producto GIM-N	14
GIM 100/15N - GIM 140/25N	15
GIM 360N	16
GIM 360NB	17
GIM 500N - GIM 500NE SPLIT - GIM 750N - GIM 750NE SPLIT	18
GIM 1000N - GIM 1000NE SPLIT	19
GIM 1500N - GIM 1500NE SPLIT	20



PRODUTTORI GHIACCIO IN SCAGLIE / FLAKE/SCALE ICE MAKERS
GLACE EN ECAILLES MACHINE GLACE ECAILLE / FABRICADORES HIELO EN ESCAMAS

Presentazione prodotto FIM/FIM product presentation/Présentation du produit FIM/Presentación del producto FIM	21
FIM 250 - FIM 400	23
FIM 600 - FIM 600E SPLIT - FIM 950 - FIM 950E SPLIT	24
FIM 1500 - FIM 1500E SPLIT - FIM 3000E SPLIT	25



PRODUTTORI GHIACCIO IN SCAGLIE PER ACQUA DOLCE E SALATA E INSTALLAZIONI ON BOARD
FLAKE/SCALE ICE MAKERS FOR FRESH / SALT WATER AND "ON BOARD" INSTALLATION
MACHINE GLACE ECAILLE POUR EAU FRAICHE/SALÉE ET INSTALLATION "ON BOARD"
FABRICADORES HIELO EN ESCAMAS PARA AGUA DULCE / SALADA Y INSTALACIÓN "ON BOARD"

Presentazione prodotto FIM NE/ FIM NE product presentation/Présentation du produit FIM NE/Presentación del producto FIM NE	26
FIM 1200 NE SPLIT - FIM 2800 NE SPLIT- FIM 4000 NE SPLIT - FIM 5600 NE SPLIT - FIM 8000 NE SPLIT	27



UNITÀ MOTOCONDENSANTI PER MODELLI SPLIT / MOTO-CONDENSING UNITS FOR SPLIT MODELS	
UNITÉS DE CONDENSATION POUR MODÈLES SPLIT / UNIDAD DE CONDENSACIÓN PARA MODELOS SPLIT	29



ACCESSORI / ACCESSORIES	
ACCESORIOS / ACCESORIOS	30



Generalità

Il funzionamento di un fabbricatore di ghiaccio si basa su tre elementi principali:

- Il COMPRESSORE, che comprime il gas
- Il CONDENSATORE, dove il gas compresso viene raffreddato e si liquefa
- L'EVAPORATORE, dove il gas si espande sottraendo calore alla superficie con cui è a contatto

Nell'evaporatore l'acqua di alimentazione, ghiaccia.

Lo strato viene quindi rimosso, in funzione del principio applicato, da una coclea o da un raschiatore. Il risultato è il ghiaccio granulare o in scaglie.

APPLICAZIONI

Alcuni utilizzi ed applicazioni:

1 - CONSERVAZIONE DEGLI ALIMENTI DURANTE IL TRASPORTO O LO STOCCAGGIO

La capacità termica del ghiaccio consente di mantenere basse temperature di conservazione per tempi più lunghi.

Particolarmente indicato per il settore ittico (produttori di ghiaccio vengono utilizzati per abbattere le temperature e preparare le cassette del pescato).

2 - CONSERVAZIONE, PRESENTAZIONE DI PRODOTTI NEI BANCHI ESPOSITIVI DI PUNTI VENDITA O CENTRI COMMERCIALI E NEL CATERING

La conservazione del prodotto deve continuare anche all'interno del punto vendita, oppure nel banco di esposizione nel settore catering, determinante per la presentazione al pubblico. Un prodotto presentato su un letto di ghiaccio comunica sensazione di freschezza e igiene.

Anche l'aspetto e la qualità del ghiaccio, per queste applicazioni, è importante. La produzione deve essere ottima, con scaglie o granuli bianchi, puri, compatti, perfetti anche dal punto di vista igienico e perfettamente drenanti dei liquidi prodotti dagli alimenti e dall'acqua di fusione.

Il ghiaccio granulare è a volte preferito, anche se ha una capacità di raffreddamento minore, perché facilmente modellabile per l'esposizione e perché conserva l'umidità del prodotto.

Applicazioni tipiche si individuano nei reparti pescheria, o nel catering o nella ristorazione in genere. Pesce, frutta, verdure, carni, latticini, succhi e prodotti di gastronomia in genere, presentati su uno strato di ghiaccio svolgono il duplice servizio di conservare e comunicare un aspetto più invitante e fresco, attirando l'attenzione sulla qualità del servizio.

3 - RAFFREDDAMENTO NEI PROCESSI PRODUTTIVI

Molti processi produttivi richiedono l'eliminazione del calore sviluppato durante il processo ed il mantenimento di un determinato livello di temperatura. Alcuni Esempi:

- Settore carni; nella produzione di carne tritata per hamburger ed insaccati (salicce) o durante il taglio
- Settore panificazione; per il mantenimento della temperatura nella fase di lievitazione
- Trattamento dei vegetali; per abbassare la temperatura nei processi di lavaggio
- Settore caseario; per la produzione di latte ghiacciato in scaglie

Altre applicazioni di ghiaccio sotto raffreddato trova utilizzo anche nel settore sanitario.

SETTORI

- Ittico (dal mercato alla vendita al dettaglio)
- Grande distribuzione (banchi esposizione prodotti freschi, surgelati sfusi, reparti pescherie)
- Laboratori carni e centri di confezionamento
- Servizi catering e ristorazione in generale
- Sanitario (wellness)
- Trasporti e impianti di stoccaggio
- Produzione di ghiaccio sfuso
- Settore edile



Principles

The ice flake makers are machines based on simple elements:

- COMPRESSOR to compress the cooling agent
- CONDENSER to cool down and liquefy the refrigerating gas
- EVAPORATOR to expand the gas by thermal exchange

The water when getting in contact with the evaporator surface, freezes.

The iced layer is, then, removed by either a scraper for flakes/scales ice or a draw plate for granular ice.

APPLICATION FIELDS

Ice makers are suitable for both retails and industrial requirements:

1 - FOOD CONSERVATION: HANDLING AND STORAGE

The high thermal capacity of the ice allows to keep low preserving temperatures in cold rooms for quite a long time.

Very popular technology amongst fish processors, dealers and retailers, for example.

2 - PRESERVATION AND PRESENTING

Preservation must be kept unaltered inside shops, supermarkets fish counters, restaurants and canteen.

The quality of food gets enhanced on an ice layer; looking fresh, clean and appealing to the consumers.

The ice, no matter whether flake or granular, must be white, pure, compact, dry, perfectly clean and draining melting water or food liquids.

Sometimes granular ice is preferred because of its moisturizing features and easy shaping.

Fruit, vegetables, juices, meat, ready meals and fish, presented on a bed of ice meet important requirements such as customer care and freshness.

3 - COOLING IN PRODUCTION PROCESSING LINES

Accurate temperature control must be granted during many production processing lines where product heating cannot be avoided:

- Meat processing industries (minced and mixed meat for hamburger and sausages preparing)
- Bakeries for bread rising
- Vegetable industries during washing process
- Chemical industry and concrete cooling

The benefits of ice are immediately spot-on.

MARKETS

- Fish industry (from market to retail sale)
- Super and iper markets distribution chains.
- Meat processors and packaging platforms
- Meat industry
- Pharmaceutical (wellness)
- Handling and storing plants
- Ice production plant
- Building business





Principes

Le fonctionnement d'une machine à glace se fonde sur trois éléments principaux:

- Un groupe compresseur qui comprend l'agent réfrigérant.
- Le condenseur où le gaz comprimé refroidit et devient, en suite, liquide.
- Le générateur de glace qui par échange thermique répand le gaz.

Le cylindre est refroidi grâce au gaz cryogénique qui s'écoule à son intérieur. Le froid est transféré directement à l'eau qui gèle et, à travers d'une filière vient transformée en grains ou en écailles par une fraise qui décolle la croute glacée.

APPLICATIONS

Les machines à glace s'adaptent à de nombreuses activités et industries.

1 - PRÉSERVATION DES ALIMENTS PENDANT TRANSPORT ET ENTREPOSAGE

La puissance frigorifique de la glace garde le niveau de température optimal du produit pour que sa vie commerciale soit prolongée.

Technologie très bien populaire, par exemple, parmi le secteur de la pêche, (aqua-culture et transformation produits de la mer) les marchands au détail et la grande distribution.

2 - CONSERVATION ET PRÉSENTATION

La préservation des produits doit être garantie au cours de leur transformation et leur vente dans les magasins et pour l'étalage de la marchandise en vitrine en ce qui concerne restauration et restauration collective.

La glace exalte la qualité des produits et leur donne un aspect frais et propre.

Notre glace, granulaire comme en écailles, blanche, pure, compacte et hygiénique draine parfaitement les liquides des aliments et l'eau de fusion.

La glace granulaire, facile à modeler et exposer, est, parfois, préférée grâce à sa capacité de garder l'humidité des produits même si performe une puissance réfrigérante inférieure.

Ces solutions trouvent application dans les industries, la marine et l'agro alimentaire. Poissons, fruits, légumes, viande, jus, fromages et les plats cuisinés, exposés sur un lit de glace, sont plus appétissants et plus faciles à vendre. Votre clientèle sera stupéfaite par la qualité du service de votre entreprise.

3 - REFROIDISSEMENT DES PRODUITS

Le Pré-refroidissement permet de baisser la température des produits pendant leur transformation. Il ralentit aussi le processus de détérioration et le développement des bactéries. Par exemple:

- Industrie de la Viande
- La glace évite le réchauffement du mélange haché pour la production de charcuterie et hamburger et apporte de l'eau à la préparation.
- Boulangerie
- Pour le contrôle de la température de l'eau contenue dans les pâtes pendant les cycles de pétrissage et lavage.
- Fruits et légumes
- Permet d'abaisser la température des produits à la récolte et pendant le nettoyage en améliorant l'aspect esthétique ainsi que sa conservation.
- Industrie fromagère

Pour la production de lait gelé en écailles.

MARCHÉS

- Pêche (de la vente en gros à celle au détail)
- La grande distribution (exposition en vitrine de produits frais et surgelés, poissonnerie)
- Restauration
- Etablissements transport et entreposage
- Industrie pharmaceutique (wellness)
- Chimique
- Béton
- Production de glace au détail
- Entreprise de construction



Generalidades

El funcionamiento de un fabricante de hielo se basa en tres elementos principales:

- El COMPRESOR, que comprime el gas refrigerante
- El CONDENSADOR, donde el gas comprimido se enfría y se produce la licuación (estado gaseoso a estado líquido)
- El EVAPORADOR, donde el gas se expande absorbiendo el calor de la superficie con la cual está en contacto

El agua se congela en el evaporador para producir hielo. Se congela al entrar en contacto con la superficie fría. El hielo que se forma se remueve a través de un "rascador" (hielo en escamas) o de una hélice (hielo granular) según el tipo de máquina que se trate.

APLICACIONES

El uso de fabricantes de hielo se extiende a variados sectores tanto industriales como comerciales. Algunos usos y aplicaciones son:

1 - CONSERVACION DE LOS ALIMENTOS DURANTE EL TRANSPORTE Y ALMACENAMIENTO

Para esta aplicación se aconseja el hielo en escamas, más drenado y más frío (-7°C). La capacidad térmica del hielo en escamas permite mantener bajas temperaturas de conservación durante tiempos más prolongados.

Particularmente indicado para el sector ictícola (fabricadores de hielo en escamas se instalan a bordo de naves pesqueras para bajar la temperatura del pescado y preparar el confeccionado del mismo).

2 - CONSERVACION Y PRESENTACION DE PRODUCTOS EN LOS BANCOS EXPOSITIVOS DE SUPERMERCADOS/CENTROS COMERCIALES O EN EL SECTOR CATERING

La conservación del producto debe continuar aún al interno del punto de venta o en los bancos de exposición en el catering, determinante esto para la presentación al público. Un producto presentado en una cama de hielo comunica una sensación de frescura e higiene.

También el aspecto y la calidad del hielo son importantes para estas aplicaciones. La producción debe ser óptima, con escamas o gránulos blancos, puros, compactos, en buen estado desde el punto de vista sanitario y perfectamente escurridos de los líquidos producidos por los alimentos y la fusión del hielo mismo.

El hielo granular es preferible en este caso, aunque si tiene una capacidad refrigerante menor, porque se puede modelar fácilmente para la exposición y porque conserva la humedad del producto refrigerado.

Aplicaciones habituales se encuentran en los bancos de pescado en supermercados, catering y en la gastronomía en general. Pescado, fruta, verdura, carne, lácteos, jugos y productos gastronómicos presentados sobre una cama de hielo tienen la doble función de conservar y expresar un aspecto más atractivo y fresco, poniendo la atención sobre la calidad del servicio.

3 - ENFRIADO DURANTE LOS PROCESOS PRODUCTIVOS

Muchos procesos productivos requieren la eliminación del calor generado durante el procesado mismo y el mantenimiento de un determinado nivel de temperatura. Algunos ejemplos:

- Sector cárnico: producción de carne picada/molida para la posterior producción de hamburguesas y embutidos o durante el corte
- Sector panificación: mantenimiento de la temperatura durante el proceso de fermentación con levadura
- Sector hortícola: bajar la temperatura durante el proceso de lavado
- Sector lácteo: producción de leche congelada en escamas
- Otras aplicaciones: sector sanitario

SECTORES

- Ictícola (del mercado a la venta al detalle)
- Centro de elaboración y confeccionamiento de la carne
- Catering y gastronomía
- Sanitario (wellness)
- Transporte y plantas de almacenamiento
- Producción de hielo
- Industria de la construcción



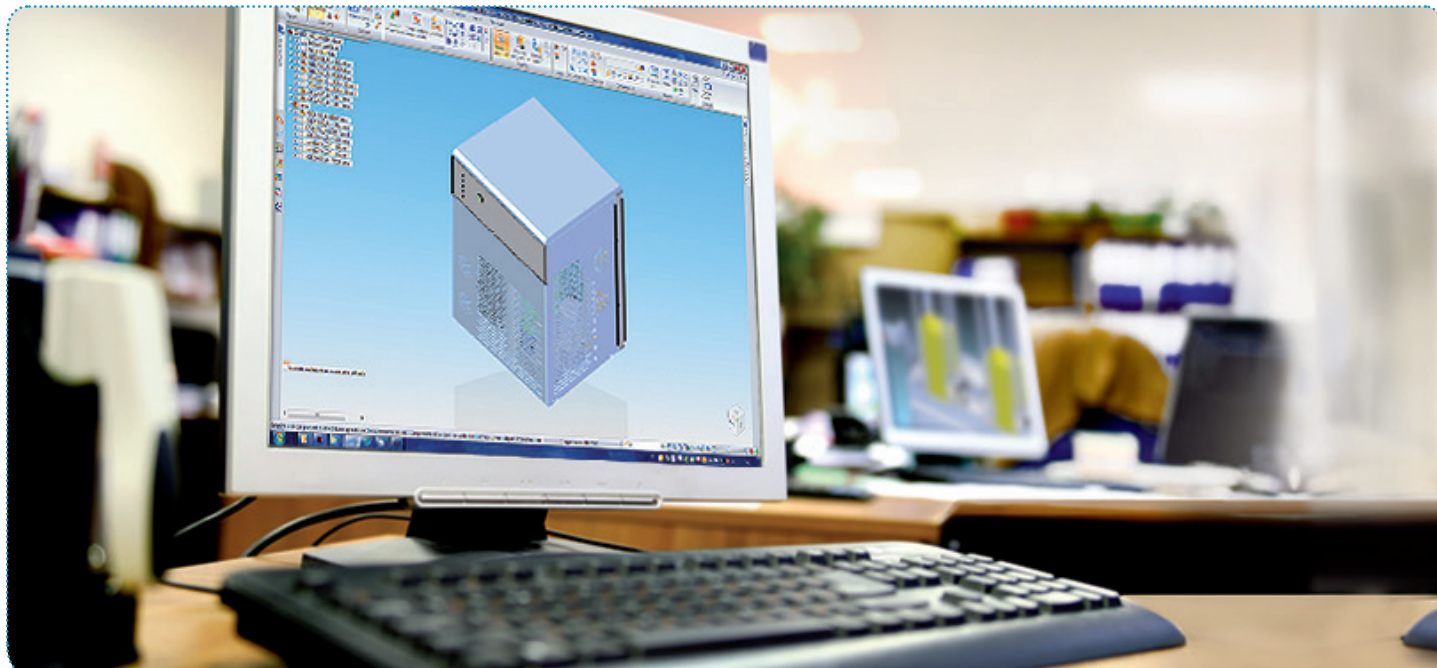

Fiducia nell'esperienza

Ice-Tek è un brand di Minerva Omega Group s.r.l. I produttori di ghiaccio Ice-Tek sono il risultato di competenze riconosciute in tutto il mondo nella progettazione di macchine e sistemi per la lavorazione e conservazione di prodotti alimentari.

L'obiettivo finale del reparto R&D, che ha sviluppato questa linea ad alta produttività, era unire la grande esperienza nella componentistica di qualità e precisione, con un design stilisticamente orientato all'essenzialità, al contenimento delle dimensioni, ma soprattutto alla funzionalità. I prodotti di questo catalogo raggiungono egregiamente questo risultato: una perfetta combinazione tra tecnologia, tecnica ed esperienza orgogliosamente "Made in Italy".

Trusted experience

Ice-Tek is a Minerva Omega Group s.r.l. brand. Ice-Tek ice makers are the end result of world-renowned experience in the design of machines and systems for food processing and preservation.

The final objective of the R&D department, which developed this high productivity line, was to team extensive experience in quality and precision components with an understated design, compact dimensions and, above all, functionality. The products in this catalogue easily meet this objective: the perfect combination of technology, technique and proud "Made in Italy" experience.

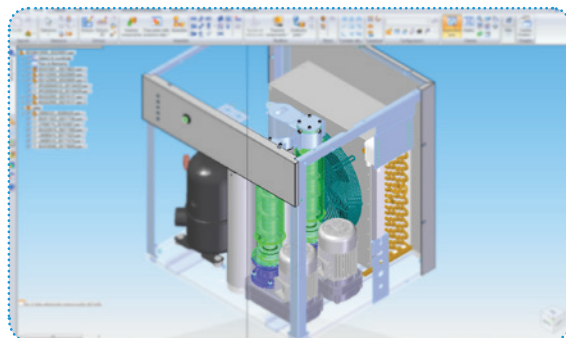

Confiance dans l'expérience

Ice-Tek est une marque de Minerva Omega Group s.r.l. Les machines à glace Ice-Tek sont le résultat de compétences reconnues dans le monde entier dans la conception de machines et de systèmes de transformation et de conservation de produits alimentaires.

L'objectif final du département R&D, qui a développé cette ligne à productivité élevée, était de joindre la grande expérience des composants de qualité et de précision avec un design stylistiquement épuré, des dimensions réduites et, surtout, une grande fonctionnalité. Les articles de ce catalogue atteignent sans conteste ce résultat : une parfaite combinaison de technologie et d'expérience orgueilleusement "Made in Italy".

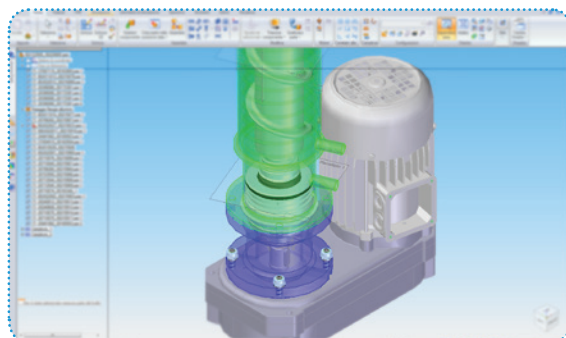

Confianza en la experiencia

Ice-Tek es una marca de Minerva Omega Group s. r. l. Las máquinas de hielo Ice-Tek son el resultado de una capacidad mundialmente reconocida en el diseño de máquinas y sistemas para la elaboración y conservación de productos alimentarios.

El objetivo final del departamento de Investigación y Desarrollo, que ha desarrollado esta línea de alta productividad, consistía en combinar una gran experiencia en la producción de componentes de calidad y precisión, con un diseño estilísticamente orientado a la esencialidad, a la reducción de las dimensiones y, sobre todo, a la funcionalidad. Los productos de este catálogo alcanzan plenamente este resultado: una perfecta combinación de tecnología, técnica y experiencia, orgullosamente made in Italy.



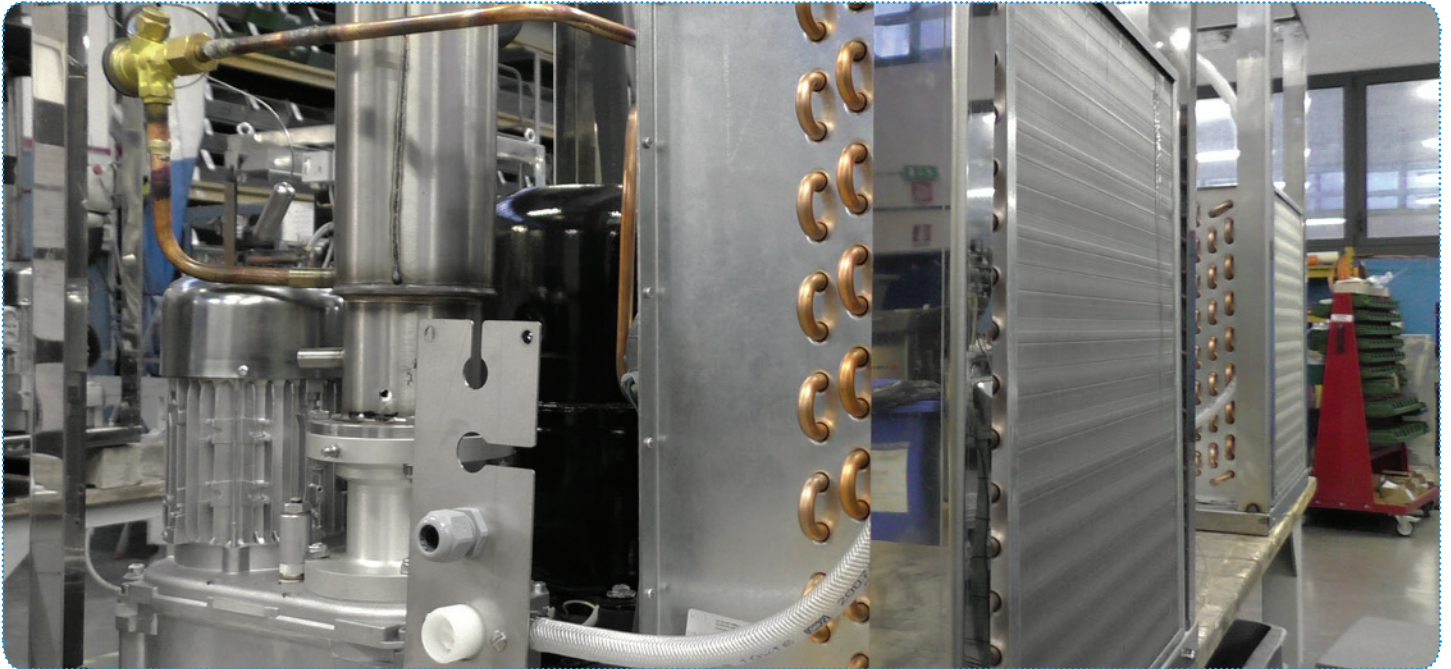

Una produzione controllata

70 anni di esperienza nelle lavorazioni meccaniche ed una filosofia orientata al massimo controllo di ogni processo produttivo automatizzato o manuale, garantisce la massima qualità delle nostre macchine. Una promessa che inizia dalla scelta delle materie prime, nei metodi di fabbricazione e prosegue fino ai controlli, ai test ambientali in camera climatica per testare gli scenari installativi più estremi e ai collaudi finali. Questa centralità è la nostra migliore garanzia. Tutti i modelli soddisfano ogni esigenza artigianale o industriale perché a differenti capacità in funzione del modello.

Controlled production

70 years' experience in mechanical processes and a philosophy focused on maximum control of each and every automated or manual production process guarantee the maximum quality of our machines. It is a promise that begins with our choice of raw materials and continues with our manufacturing methods, controls, environmental tests in climatic chamber to test the most extreme installation scenarios, right through to final inspections. This central focus is our best guarantee. With a broad range of different capacities, there are models to meet the requirements of small to large-scale business.

Une production contrôlée

Quelque 70 ans d'expérience en mécanique et une philosophie orientée au contrôle maximal de chaque processus de production automatisé ou manuel : c'est ce qui assure la qualité maximale de nos machines. Une promesse qui commence par le choix des matières premières et des procédés de fabrication, et qui se poursuit jusqu'aux contrôles, aux essais en chambre climatique destinés à tester les conditions d'installation les plus extrêmes et aux essais finaux. Cette centralité est notre meilleure garantie.

Tous les modèles satisfont toutes les exigences artisanales ou industrielles, avec des capacités différentes en fonction du modèle.

Una producción controlada

Setenta años de experiencia en la elaboración mecánica y una filosofía orientada al máximo control de cada proceso de producción, automatizado o manual, garantizan la insuperable calidad de nuestras máquinas. Una promesa que comienza con la elección de las materias primas y de los métodos de fabricación, y continúa hasta los controles, las pruebas ambientales en cámara climática (para comprobar las situaciones de instalación más extremas) y los ensayos finales. Esta centralidad representa nuestra mejor garantía.

Nuestra gama de aparatos satisface cualquier necesidad de producción, artesanal o industrial, ya que ofrece diferentes capacidades en función del modelo.





GHIACCIO CUBETTO PIENO 18-36 GR - 18-36 GR FULL ICE CUBE GLACON PLEIN, 18-36 GR - CUBITO MACIZO 18-36 GR

Cubetto pieno da 18-36 gr, alta densità cristallino e puro.

Adattabile a qualsiasi forma del bicchiere, raffredda senza annacquare.
Attrezzature destinate ad applicazioni residenziali e commerciali.
Ideali per la ristorazione, il settore alberghiero e dell'intrattenimento.
Evaporatore orizzontale, sistema a spruzzo.
Vasca raccolta ghiaccio integrata.

Full 18-36 gr ice cube, high density, crystal clear.

*Dimensioned to fit any glass shape, for long lasting drink cooling without watering.
The perfect solution for both domestic and commercial applications: catering, hotel trades, leisure time as well as entertainment.
Horizontal evaporator, sprayer system.
Self contained ice collecting bin.*

Glacon plein, 18-36 gr haute densite, pure, structure cristalline.

Dimensionne pour s'adapter à toutes formes de verre. Refroidie sans mouiller.
la solution ideale soi pour d'applications residentielle que commerciales: restauration collective, hotellerie, loisirs et entertainment.
Evaporateur horizontal, systeme a pulverisation.
Bac à glace incorporee.

Cubito macizo 18-36 gr, alta densidad, cristallino y puro.

Se adapta a cualquier forma de vaso, enfría sin "aguar" la bebida.
Máquinas destinadas a usos residenciales y comerciales.
Ideales para restaurantes, hoteles y tiempo libre/entretenimiento.
Evaporator horizontal, sistema de aspersión.
Cuba recolección hielo incorporada.



CUBETTO/ICE CUBES*



CIM 20/6 - CIM 30/10 - CIM 45/15

PRODUTTORI GHIACCIO CUBETTO PIENO - FULL CUBE ICE MAKERS

MACHINES À GLACE GLAÇONS PLEIN - FABRICADORES HIELO EN CUBITOS MACIZOS



20-30-45 kg/24 h



18 gr 36 gr

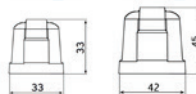

Cubetto/Cube/Glaçons/Cubitos

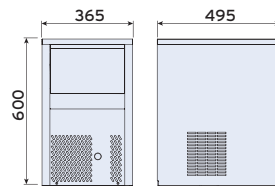

CIM 20/6

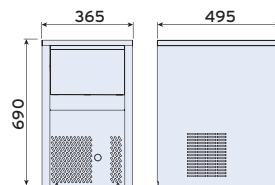

CIM 30/10

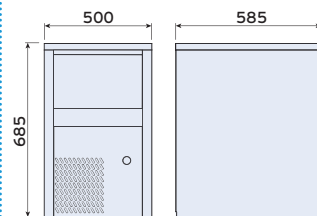

CIM 45/15



- Costruzione in acciaio inox e materiali idonei al contatto con gli alimenti
- Gas R452A
- **Vasca raccolta ghiaccio integrata**
- Condensazione (A) aria o (W) acqua
- Controlli elettronici
- Voltaggi speciali, su richiesta
- Macchine rispondenti alle normative di igiene e di sicurezza in vigore
- **Condizioni di lavoro standard: temperatura acqua 15°C temperatura ambiente 20°C**
- Consigliata installazione sistema dosatore sale anticalcare



- *Construction in stainless steel and specific materials approved for contact with food stuff*
- *Gas R452A*
- **Self contained ice collecting bin**
- *(A) Air or W (Water) condensing*
- *Electronic controls*
- *Special voltages, on request*
- *Machines comply with hygiene and safety regulations*
- **Standard working conditions: incoming water temperature 15°C environment air temperature 20°C**
- *Highly recommended the installation of salt dosing unit to prevent scale built-up of limestone*



- Construction en acier inox et matériaux pour aliments
- Gaz R452A
- **Bac à glace incorporée**
- Condensation (A) air ou (W) eau control électronique
- Tensions spéciales, sur demande
- Machines conformes aux normes en vigueur en matière d'hygiène et de sécurité
- **Conditions de travail standard: température eau 15°C température environnement 20°C**
- Une unité de dosage de poudre pour empêcher le calcaire est fortement recommandée



- Estructura de acero inoxidable y materiales para alimentos
- Gas R452A
- **Cuba recolección hielo incorporada**
- Comandos electrónicos condensación (A) aire o (W) agua
- Voltajes especiales a petición
- Máquinas conformes a las normas vigentes en materia de higiene y seguridad
- **Condiciones de trabajo standards: temperatura entrada agua: 15°C temperatura ambiente: 20°C**
- Recomendado instalación sistema dosificador de sales para evitar incrustaciones de calcio

	CIM 20/6 (18 gr)	CIM 30/10 (18 gr)	CIM 30/10L (36 gr)	CIM 45/15 (18 gr)	CIM 45/15L (36 gr)
Produzione - Productivity Production - Producción	20 kg/24 h 1176 cubetti/cubes/ glaçon/cubitos	30 kg/24 h 1764 cubetti/cubes/ glaçon/cubitos	30 kg/24 h 1764 cubetti/cubes/ glaçon/cubitos	45 kg/24 h 2647 cubetti/cubes/ glaçon/cubitos	45 kg/24 h 2647 cubetti/cubes/ glaçon/cubitos
Capacità deposito - Storage capacity Capacite bac - Capacidad depósito	5 kg 294 cubetti/cubes/ glaçon/cubitos approx	10 kg 588 cubetti/cubes/ glaçon/cubitos approx	10 kg 588 cubetti/cubes/ glaçon/cubitos approx	15 kg 882 cubetti/cubes/ glaçon/cubitos approx	15 kg 882 cubetti/cubes/ glaçon/cubitos approx
Potenza elettrica - Electrical Power Puissance électrique - Potencia eléctrica	0,35 kW	0,45 kW	0,45 kW	0,65 kW	0,65 kW
Peso netto - Net weight - Poids net - Peso neto	33 kg	36 kg	36 kg	52 kg	52 kg
Tensione nominale - Volt Rated Tension nominale - Tensión nominal	V230/1/50Hz	V230/1/50Hz	V230/1/50Hz	V230/1/50Hz	V230/1/50Hz

ACCESSORI - ACCESSORIES - ACCESSOIRES - ACCESORIOS (pag. 30-33)





50-85-100 kg/24 h



18 gr 36 gr

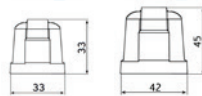

Cubetto/Cube/Glaçons/Cubitos

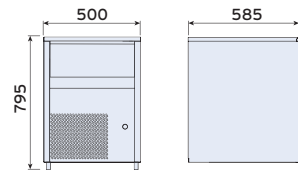

CIM 50/25

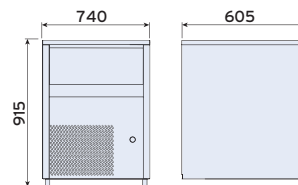

CIM 85/40

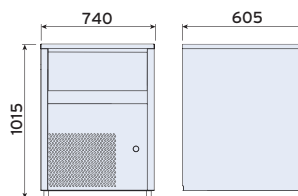

CIM 100/60



- Costruzione in acciaio inox e materiali idonei al contatto con gli alimenti
- Gas R452A
- **Vasca raccolta ghiaccio integrata**
- Condensazione (A) aria o (W) acqua
- Controlli elettronici
- Voltaggi speciali, su richiesta
- Macchine rispondenti alle normative di igiene e di sicurezza in vigore
- **Condizioni di lavoro standard:**
temperatura acqua 15°C
temperatura ambiente 20°C
- Consigliata installazione sistema dosatore sale anticalcare



- *Construction in stainless steel and specific materials approved for contact with food stuff*
- *Gas R452A*
- **Self contained ice collecting bin**
- *(A) Air or W (Water) condensing*
- *Electronic controls*
- *Special voltages, on request*
- *Machines comply with hygiene and safety regulations*
- **Standard working conditions:**
*incoming water temperature 15°C
environment air temperature 20°C*
- *Highly recommended the installation of salt dosing unit to prevent scale built-up of limestone*



- Construction en acier inox et matériaux pour aliments
- Gaz R452A
- **Bac à glace incorporée**
- Condensation (A) air ou (W) eau control électronique
- Tensions spéciales, sur demande
- Machines conformes aux normes en vigueur en matière d'hygiène et de sécurité
- **Conditions de travail standard:**
température eau 15°C
température environnement 20°C
- Une unité de dosage de poudre pour empêcher le calcaire est fortement recommandée



- *Estructura de acero inoxidable y materiales para alimentos*
- *Gas R452A*
- **Cuba recolección hielo incorporada**
- *Comandos electronicos condensacion (A) aire o (W) agua*
- *Voltajes especiales a petición*
- *Máquinas conformes a las normas vigentes en materia de higiene y seguridad*
- **Condiciones de trabajo standards:**
*temperatura entrada agua: 15°C
temperatura ambiente: 20°C*
- *Recomendado instalación sistema dosificador de sales para evitar incrustaciones de calcio*

	CIM 50/25 (18 gr)	CIM 50/25L (36 gr)	CIM 85/40 (18 gr)	CIM 80/40L (36 gr)	CIM 90/60L (36 gr)	CIM 100/60 (18 gr)
Produzione - Productivity Production - Producción	50 kg/24 h 2941 cubetti/cubes/ glaçon/cubitos	50 kg/24 h 2941 cubetti/cubes/ glaçon/cubitos	85 kg/24 h 4705 cubetti/cubes/ glaçon/cubitos	80 kg/24 h 4705 cubetti/cubes/ glaçon/cubitos	90 kg/24 h 5310 cubetti/cubes/ glaçon/cubitos	100 kg/24 h 5882 cubetti/cubes/ glaçon/cubitos
Capacità deposito - Storage capacity - Capacite bac - Capacidad depósito	25 kg 1470 cubetti/cubes/ glaçon/cubitos approx	25 kg 1470 cubetti/cubes/ glaçon/cubitos approx	40 kg 2352 cubetti/cubes/ glaçon/cubitos approx	40 kg 2352 cubetti/cubes/ glaçon/cubitos approx	60 kg 3529 cubetti/cubes/ glaçon/cubitos approx	60 kg 3529 cubetti/cubes/ glaçon/cubitos approx
Potenza elettrica - Electrical Power - Puissance électrique - Potencia eléctrica	0,8 kW	0,8 kW	0,9 kW	0,9 kW	1,0 kW	1,0 kW
Peso netto - Net weight - Poids net - Peso neto	55 kg	55 kg	72 kg	72 kg	87 kg	87 kg
Tensione nominale - Volt Rated - Tension nominale - Tensión nominal	V230/1/50Hz	V230/1/50Hz	V230/1/50Hz	V230/1/50Hz	V230/1/50Hz	V230/1/50Hz

ACCESSORI - ACCESSORIES - ACCESSOIRES - ACCESORIOS (pag. 30-33)



CIM 140L - CIM 165/75 - CIM 165 - CIM 280L - CIM 300

PRODUTTORI GHIACCIO CUBETTO PIENO - FULL CUBE ICE MAKERS

MACHINES À GLACE GLAÇONS PLEIN - FABRICADORES HIELO EN CUBITOS MACIZOS



- Costruzione in acciaio inox e materiali idonei al contatto con gli alimenti
- Gas R452A
- **Vasca raccolta ghiaccio integrata per CIM 165/75**
- Condensazione (A) aria o (W) acqua
- Controlli elettronici
- Voltaggi speciali, su richiesta
- Macchine rispondenti alle normative di igiene e di sicurezza in vigore
- **Condizioni di lavoro standard: temperatura acqua 15°C temperatura ambiente 20°C**
- Consigliata installazione sistema dosatore sale anticallcare

- *Construction in stainless steel and specific materials approved for contact with food stuff*
- *Gas R452A*
- **Built-in ice collection tank for CIM 165/75**
- *(A) Air or W (Water) condensing*
- *Electronic controls*
- *Special voltages, on request*
- *Machines comply with hygiene and safety regulations*
- **Standard working conditions: incoming water temperature 15°C environment air temperature 20°C**
- *Highly recommended the installation of salt dosing unit to prevent scale built-up of limestone*

- Construction en acier inox et matériaux pour aliments
- Gaz R452A
- **Bac de récupération de la glace intégré pour CIM 165/75**
- Condensation (A) air ou (W) eau control électronique
- Tensions spéciales, sur demande
- Machines conformes aux normes en vigueur en matière d'hygiène et de sécurité
- **Conditions de travail standard: température eau 15°C température environnement 20°C**
- Une unité de dosage de poudre pour empêcher le calcaire est fortement recommandée

- *Estructura de acero inoxidable y materiales para alimentos*
- *Gas R452A*
- **Cuba colectora de hielo integrada en CIM 165/75**
- *Comandos electronicos condensacion (A) aire o (W) agua*
- *Voltajes especiales a petición*
- *Máquinas conformes a las normas vigentes en materia de higiene y seguridad*
- **Condiciones de trabajo standards: temperatura entrada agua: 15°C temperatura ambiente: 20°C**
- *Recomendado instalación sistema dosificador de sales para evitar incrustaciones de calcio*

	CIM 140L (36 gr)	CIM 165/75 (18 gr)	CIM 165 (18 gr)	CIM 280L (36 gr)	CIM 300 (18 gr)
Produzione - Productivity Production - Producción	140 Kg/24 h 9520 cubetti/cubes/ glaçon/cubitos	165 Kg/24 h 9735 cubetti/cubes/ glaçon/cubitos	165 kg/24 h 9735 cubetti/cubes/ glaçon cubitos	280 kg/24 h 19040 cubetti/cubes/ glaçon cubitos	300 kg/24 h 17650 cubetti/cubes/ glaçon/cubitos
Capacità deposito - Storage capacity Capacite bac - Capacidad depósito	-	75 kg 4411 cubetti/cubes/ glaçon/cubitos approx	-	-	-
Potenza elettrica - Electrical Power Puissance électrique - Potencia eléctrica	1,7 kW	1,7 kW	1,7 kW	2,7 kW	2,7 kW
Peso netto - Net weight Poids net - Peso neto	97 kg	113 kg	97 kg	153 kg	153 kg
Tensione nominale - Volt Rated Tension nominale - Tensión nominal	V230/1/50Hz	V230/1/50Hz	V230/1/50Hz (*)	V230/1/50Hz (*)	V230/1/50Hz (*)

ACCESSORI - ACCESSORIES - ACCESSOIRES - ACCESORIOS (pag. 30-33)



(*) CIM 165-CIM 300: fornite senza pulsante START/STOP (eventuale adeguamento impianto del cliente non incluso) - CIM 165-CIM 300: not included START/STOP switch (eventual adaptation on electrical box is not included) - CIM 165-CIM 300: non inclus Commutateur START / STOP (l'adaptation éventuelle sur panneau électrique n'est pas incluse) / CIM 165-CIM 300: sin pulsante START/STOP (eventual adaptación cuadro eléctrico del cliente no incluida)

Ghiaccio granulare

Prodotto ad una temperatura di 0°C, ha un grado di umidità ideale e variabile dal 15% al 25%, ottimale per esporre al pubblico i prodotti freschi mantenendoli perfettamente refrigerati e idratati al giusto grado di umidità. Il colore è brillante, puro, indicato per modellazione, tipicamente consigliato nella preparazione dei banchi in vista (banchi peschierie al dettaglio o nei supermercati) o per esporre i prodotti nel catering. Anche se disposto in strati sottili, offre un'ottima copertura e un mantenimento ottimale della temperatura, oltre che avere una resa estetica ottimale.

L'evaporatore, cuore della produzione, è costituito da un cilindro cavo al cui interno, in un'apposita intercapedine, evapora il gas R404a che ghiaccia l'acqua immessa nel cilindro stesso e da un estrusore la cui sommità impedisce l'eccessivo compattamento del ghiaccio.

Granular ice

Produced at a temperature of 0°C, it has an ideal humidity level variable between 15% and 25%, optimal for public display of fresh produce, keeping it perfectly chilled and hydrated at the right humidity level. Bright, pure colour, indicated for moulding, typically recommended for display counters (fishmongers and supermarkets) or for displaying products in catering. Its fine layers offer excellent coverage and optimum temperature stability, as well as delivering excellent aesthetic appeal.

The evaporator, the heart of production, is made up of a hollow cylinder, inside which a cavity allows evaporation of the R404a gas, which freezes the water fed into the cylinder, and an extruder, the top of which prevents the ice being excessively compacted.

Glace granulaire

Produite à une température de 0°C, elle présente un degré d'humidité idéal et variable de 15% à 25%, optimal pour exposer à l'intention du public les produits frais en les maintenant parfaitement réfrigérés et hydratés au juste degré d'humidité. La couleur est brillante, pure, indiquée pour le modelage, typiquement conseillée dans la préparation des étalages (étalages de poissonnerie au détail ou dans les supermarchés) ou pour exposer les produits dans le catering. Même si elle est disposée en couches fines, elle offre une excellente couverture et un maintien optimal de la température, joints à un effet esthétique optimal.

L'évaporateur, coeur de la production, est constitué d'un cylindre creux à l'intérieur duquel, dans une poche prévue à cet effet, s'évapore le gaz R404a qui congèle l'eau introduite dans le cylindre, et d'une extrudeuse dont la partie supérieure empêche le tassement excessif de la glace.

Hielo granular

Producido a una temperatura de 0 °C, tiene un grado de humedad ideal que oscila entre el 15 y el 25 %, perfecto para exponer al público productos frescos, manteniéndolos perfectamente refrigerados e hidratados con el correcto grado de humedad. El color es brillante, puro, ideal para la modelación, típicamente recomendado para la preparación de mostradores a la vista (para pescaderías minoristas y en los supermercados) o para exponer productos en servicios de catering. Incluso si se coloca en capas delgadas, ofrece una óptima cobertura y un mantenimiento ideal de la temperatura, además de una calidad estética insuperable.

El evaporador, corazón de la producción, está constituido por un cilindro hueco, en cuyo interior, en una cámara de aislamiento, se evapora el gas R404a que congela el agua inyectada en el cilindro, y por un extrusor cuya parte superior impide la excesiva compactación del hielo.



100-140 kg/24 h

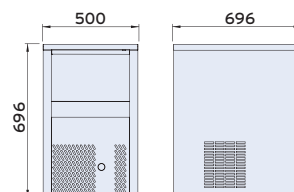

GIM 100/15N

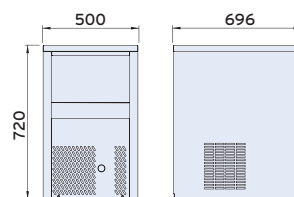

GIM 140/25N



- Costruzione in acciaio inox e materiali idonei al contatto con gli alimenti
- **Vasca raccolta ghiaccio integrata**
- Gas R452A
- Condensazione (A) aria o (W) acqua
- Controlli meccanici
- Voltaggi speciali, su richiesta
- Comandi "ON-OFF" a bordo macchina
- Macchine rispondenti alle normative di igiene e di sicurezza in vigore
- **Condizioni di lavoro standard:**
 temperatura acqua 15°C
 temperatura ambiente 20°C



- Construction in stainless steel and specific materials approved for contact with food stuff
- **Self contained ice collecting bin**
- Gas R452A
- (A) Air or W (Water) condensing
- Mechanical control
- Special voltages, on request
- "ON-OFF" controls on board the machine
- Machines comply with hygiene and safety regulations
- **Standard working conditions:**
 incoming water temperature 15°C
 environment air temperature 20°C



- Construction en acier inox et matériaux pour aliments
- **Bac à glace incorporée**
- Gaz R452A
- Condensation (A) air ou (W) eau control mécanique
- Versions Compact et Split
- Tensions spéciales, sur demande
- Commandes "ON-OFF" sur la machine
- Machines conformes aux normes en vigueur en matière d'hygiène et de sécurité
- **Conditions de travail standard:**
 température eau 15°C
 température environnement 20°C



- Estructura de acero inoxidable y materiales para alimentos
- **Cuba recolección hielo incorporada**
- GAS R452A
- Comandos mecánicos
- Condensación (A) aire o (W) agua
- Voltajes especiales a petición
- Mandos ON/OFF instalados en la máquina
- Máquinas conformes a las normas vigentes en materia de higiene y seguridad
- **Condiciones de trabajo standards:**
 temperatura entrada agua: 15°C
 temperatura ambiente: 20°C

	GIM 100/15N	GIM 140/25N
Produzione - Productivity - Production - Producción	100 kg/24 h	140 kg/24 h
Capacità deposito - Storage capacity Capacité bac - Capacidad depósito	15 kg	25 kg
Temperatura ghiaccio - Ice temperature Température de la glace - Temperatura del hielo	0°C	0°C
Potenza elettrica - Electrical Power Puissance électrique - Potencia eléctrica	0,6 kW	0,6 kW
Peso netto - Net weight - Poids net - Peso neto	64 kg	69 kg
Tensione nominale - Volt Rated Tension nominale - Tensión nominal	V230/1/50Hz	V230/1/50Hz

ACCESSORI - ACCESSORIES - ACCESSOIRES - ACCESORIOS (pag. 30-33)



GIM 360N

PRODUTTORI GHIACCIO GRANULARE - GRANULAR ICE MAKERS
MACHINES À GLACE EN GRAINS - FABRICADORES HIELO GRANULAR





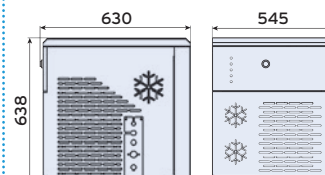

360 kg/24 h



GIM 360N



- | | | | |
|---|---|--|--|
|  <ul style="list-style-type: none"> • Costruzione in acciaio inox e materiali idonei al contatto con gli alimenti • Gas R452A • Condensazione (A) aria** • Voltaggi speciali, su richiesta • Comandi "ON-OFF" a bordo macchina • Macchine rispondenti alle normative di igiene e di sicurezza in vigore • Condizioni di lavoro standard:
temperatura acqua 15°C
temperatura ambiente 20°C • Sensore "troppo pieno" integrato |  <ul style="list-style-type: none"> • Construction in stainless steel and specific materials approved for contact with food stuff • Gas R452A • (A) Air condensing** • Special voltages, on request • "ON-OFF" controls on board the machine • Machines comply with hygiene and safety regulations • Standard working conditions:
incoming water temperature 15°C
environment air temperature 20°C • Built-in "overflow" sensor |  <ul style="list-style-type: none"> • Construction en acier inox et matériaux pour aliments • Gaz R452A • Condensation (A) air** • Tensions spéciales, sur demande • Commandes "ON-OFF" sur la machine • Machines conformes aux normes en vigueur en matière d'hygiène et de sécurité • Conditions de travail standard:
température eau 15°C
température environnement 20°C • Capteur "trop plein" intégré |  <ul style="list-style-type: none"> • Estructura de acero inoxidable y materiales para alimentos • GAS R452A • Condensación (A) aire** • Voltajes especiales a petición • Mandos ON/OFF instalados en la máquina • Máquinas conformes a las normas vigentes en materia de higiene y seguridad • Condiciones de trabajo standards:
temperatura entrada agua: 15°C
temperatura ambiente: 20°C • Sensor "llenado" integrado |
|---|---|--|--|

	GIM 360N
Produzione - Productivity - Production - Producción	360 kg/24 h
Temperatura ghiaccio - Ice temperature Température de la glace - Temperatura del hielo	0°C
Potenza elettrica - Electrical Power Puissance électrique - Potencia eléctrica	1,09 kW
Peso netto - Net weight - Poids net - Peso neto	85 kg
Tensione nominale - Volt Rated Tension nominale - Tensión nominal	V230/1/50Hz

ACCESSORI - ACCESSORIES - ACCESSOIRES - ACCESORIOS (pag. 30-33)



** Condensazione ad acqua (W) da confermare - Water (W) condensing to be confirmed - Condensation (W) eau à confirmer - Condensación (W) agua a confirmar



GIM 360 NB

PRODUTTORI GHIACCIO GRANULARE (MODELLO SOTTO BANCO) - GRANULAR ICE MAKERS (UNDERCOUNTER MODEL)
MACHINES À GLACE EN GRAINS (MODÈL SOUS LE COMPTOIR) - FABRICADORES HIELO GRANULAR (MODELO BAJO MESADA)



360 kg/24 h



GRANULAR ICE

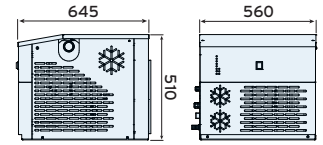

GIM 360 NB

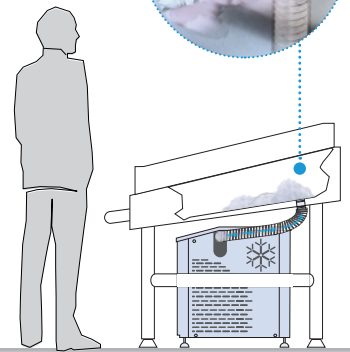
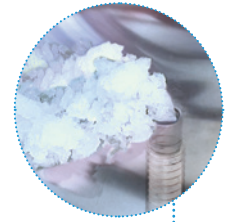

- **Modello Adatto per installazione sottobanco**
- Costruzione in acciaio inox e materiali idonei al contatto con gli alimenti
- Gas R452A
- Condensazione (A) aria**
- Voltaggi speciali, su richiesta
- Comandi "ON-OFF" a bordo macchina
- Macchine rispondenti alle normative di igiene e di sicurezza in vigore
- **Condizioni di lavoro standard:**
temperatura acqua 15°C
temperatura ambiente 20°C

OPTIONAL
• Kit di connessione al banco
(Include tubo e flangia)



- **Model Suitable for undercounter installations**
- Construction in stainless steel and specific materials approved for contact with food stuff
- Gas R452A
- (A) Air condensing**
- Special voltages, on request
- "ON-OFF" controls on board the machine
- Machines comply with hygiene and safety regulations
- **Standard working conditions:**
incoming water temperature 15°C
environment air temperature 20°C

OPTIONAL
• Connecting Kit to the counter
(It includes pipe and flange)



- **Modèle adapté pour installations sous les comptoirs**
- Construction en acier inox et matériaux pour aliments
- Gaz R452A
- Condensation (A) air**
- Tensions spéciales, sur demande
- Commandes "ON-OFF" sur la machine
- Machines conformes aux normes en vigueur en matière d'hygiène et de sécurité
- **Conditions de travail standard:**
température eau 15°C
température environnement 20°C

OPTIONAL
• Kit de connexion au comptoir
(il comprend tuyau et bride)



- **Modelo apto para instalación bajo mesada/banco**
- Estructura de acero inoxidable y materiales para alimentos
- GAS R452A
- Condensación (A) aire**
- Voltajes especiales a petición
- Mandos ON/OFF instalados en la máquina
- Máquinas conformes a las normas vigentes en materia de higiene y seguridad
- **Condiciones de trabajo standards:**
temperatura entrada agua: 15°C
temperatura ambiente: 20°C

OPTIONAL
• Kit descarga
(Intergase + tubo)

	GIM 360 NB
Produzione - Productivity - Production - Producción	360 kg/24 h
Temperatura ghiaccio - Ice temperature Température de la glace - Temperatura del hielo	0°C
Potenza elettrica - Electrical Power Puissance électrique - Potencia eléctrica	1,09 kW
Peso netto - Net weight - Poids net - Peso neto	85 kg
Tensione nominale - Volt Rated Tension nominal - Tensión nominal	V230/1/50Hz

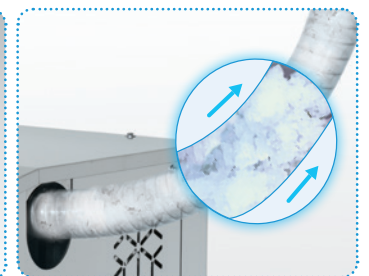
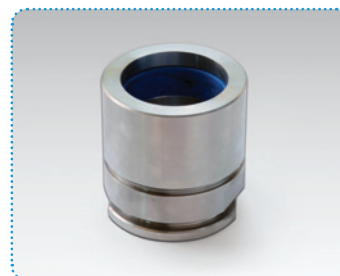

** Condensazione ad acqua (W) da confermare - Water (W) condensing to be confirmed - Condensation (W) eau à confirmer - Condensación (W) agua a confirmar

GIM 500N - GIM 500NE SPLIT - GIM 750N - GIM 750NE SPLIT

PRODUTTORI GHIACCIO GRANULARE - GRANULAR ICE MAKERS
MACHINES À GLACE EN GRAINS - FABRICADORES HIELO GRANULAR



500 - 750 kg/24 h

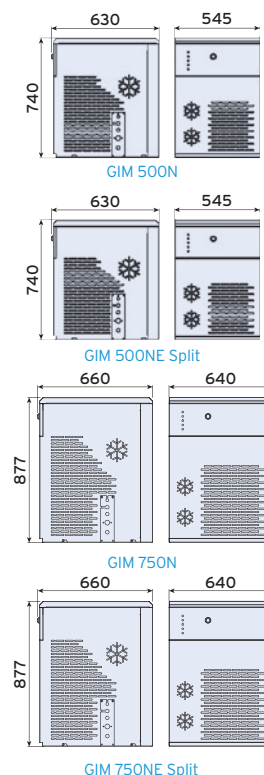

- Costruzione in acciaio inox e materiali idonei al contatto con gli alimenti
 - Gas R452A
 - Condensazione (A) aria**
 - Versioni Compact e Split*
 - Voltaggi speciali, su richiesta
 - Comandi "ON-OFF" a bordo macchina
 - Macchine rispondenti alle normative di igiene e di sicurezza in vigore
 - Condizioni di lavoro standard:**
temperatura acqua 15°C
temperatura ambiente 20°C
 - Sensore "troppo pieno" integrato
- Construction in stainless steel and specific materials approved for contact with food stuff
 - Gas R452A
 - (A) Air condensing**
 - Compact and Split* versions
 - Special voltages, on request
 - "ON-OFF" controls on board the machine
 - Machines comply with hygiene and safety regulations
 - Standard working conditions:**
incoming water temperature 15°C
environment air temperature 20°C
 - Built-in "overflow" sensor
- Construction en acier inox et matériaux pour aliments
 - Gaz R452A
 - Condensation (A) air**
 - Versions Compact et Split*
 - Tensions spéciales, sur demande
 - Commandes "ON-OFF" sur la machine
 - Machines conformes aux normes en vigueur en matière d'hygiène et de sécurité
 - Conditions de travail standard:**
température eau 15°C
température environnement 20°C
 - Capteur "trop plein" intégré
- Estructura de acero inoxidable y materiales para alimentos
 - GAS R452A
 - Condensación (A) aire**
 - Versiones Compact y Split*
 - Voltajes especiales a petición
 - Mandos ON/OFF instalados en la máquina
 - Máquinas conformes a las normas vigentes en materia de higiene y seguridad
 - Condiciones de trabajo standards:**
temperatura entrada agua: 15°C
temperatura ambiente: 20°C
 - Sensor "llenado" integrado

	GIM 500N	GIM 500NE Split*	GIM 750N	GIM 750NE Split*
Produzione - Productivity - Production - Producción	500 kg/24 h	500 kg/24 h	750 kg/24 h	750 kg/24 h
Temperatura ghiaccio - Ice temperature Température de la glace - Temperatura del hielo	0°C	0°C	0°C	0°C
Potenza frigorifera richiesta - Refrigerating capacity required Capacité frigorifique nécessaire - Capacidad frigorífica necesaria	-	1,73 kW (EN 12900-18°C +45°C)	-	3,3 kW (EN 12900-18°C +45°C)
Potenza elettrica - Electrical Power Puissance électrique - Potencia eléctrica	1,4 kW	0,4 kW	2,4 kW	0,40 kW
Peso netto - Net weight - Poids net - Peso neto	98 kg	65 kg	128 kg	85 kg
Tensione nominale - Volt Rated Tension nominale - Tensión nominal	V230/1/50Hz	V230/1/50Hz	V400/3/50Hz	V230/1/50Hz

ACCESSORI - ACCESSORIES - ACCESSOIRES - ACCESORIOS (pag. 30-33)



* Valvola KVP esclusa (optional) - KVP valve not included (optional) - Valve KVP exclue (en option) - Válvula KVP no incluida (opcional)
** Condensazione ad acqua (W) da confermare - Water (W) condensing to be confirmed - Condensation (W) eau à confirmer - Condensación (W) agua a confirmar



GIM 1000N - GIM 1000NE SPLIT
 PRODUTTORI GHIACCIO GRANULARE - GRANULAR ICE MAKERS
 MACHINES À GLACE EN GRAINS - FABRICADORES HIELO GRANULAR



1000 kg/24 h

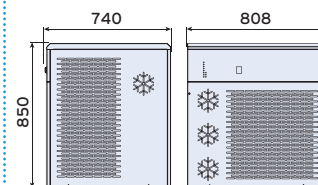

GIM 1000N

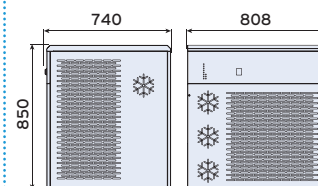

GIM 1000NE Split*

- Costruzione in acciaio inox e materiali idonei al contatto con gli alimenti
 - Gas R452A
 - Condensazione (A) aria
 - Versioni Compact e Split*
 - Voltaggi speciali, su richiesta
 - Comandi "ON-OFF" a bordo macchina
 - Macchine rispondenti alle normative di igiene e di sicurezza in vigore
 - **Condizioni di lavoro standard:**
temperatura acqua 15°C
temperatura ambiente 20°C
 - Sensore "troppo pieno" integrato
- Construction in stainless steel and specific materials approved for contact with food stuff
 - Gas R452A
 - (A) Air condensing
 - Compact and Split* versions
 - Special voltages, on request
 - "ON-OFF" controls on board the machine
 - Machines comply with hygiene and safety regulations
 - **Standard working conditions:**
incoming water temperature 15°C
environment air temperature 20°C
 - Built-in "overflow" sensor
- Construction en acier inox et matériaux pour aliments
 - Gaz R452A
 - Condensation (A) air
 - Versions Compact et Split*
 - Tensions spéciales, sur demande
 - Commandes "ON-OFF" sur la machine
 - Machines conformes aux normes en vigueur en matière d'hygiène et de sécurité
 - **Conditions de travail standard:**
température eau 15°C
température environnement 20°C
 - Capteur "trop plein" intégré
- Estructura de acero inoxidable y materiales para alimentos
 - GAS R452A
 - Condensación (A) aire
 - Versiones Compact y Split*
 - Voltajes especiales a petición
 - Mandos ON/OFF instalados en la máquina
 - Máquinas conformes a las normas vigentes en materia de higiene y seguridad
 - **Condiciones de trabajo standards:**
temperatura entrada agua: 15°C
temperatura ambiente: 20°C
 - Sensor "llenado" integrado

	GIM 1000N	GIM 1000NE Split*
Produzione - Productivity - Production - Producción	1000 kg/24 h	1000 kg/24 h
Temperatura ghiaccio - Ice temperature Température de la glace - Temperatura del hielo	0°C	0°C
Potenza frigorifera richiesta - Refrigerating capacity required Capacité frigorifique nécessaire - Capacidad frigorífica necesaria	-	6,8 kW (EN 12900-18°C +45°C)
Potenza elettrica - Electrical Power Puissance électrique - Potencia eléctrica	4,4 kW	0,80 kW
Peso netto - Net weight - Poids net - Peso neto	203 kg	140 kg
Tensione nominale - Volt Rated Tension nominale - Tensión nominal	V400/3/50Hz	V230/1/50Hz

ACCESSORI - ACCESSORIES - ACCESSOIRES - ACCESORIOS (pag. 30-33)



* Valvola KVP esclusa (optional) - KVP valve not included (optional) - Valve KVP exclue (en option) - Válvula KVP no incluida (opcional)

GIM 1500N - GIM 1500NE SPLIT

PRODUTTORI GHIACCIO GRANULARE - GRANULAR ICE MAKERS
MACHINES À GLACE EN GRAINS - FABRICADORES HIELO GRANULAR



1500 kg/24 h

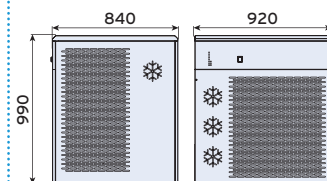

GIM 1500N

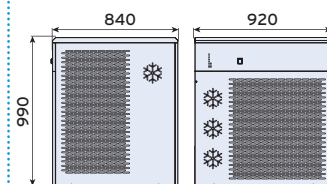

GIM 1500NE Split



- Costruzione in acciaio inox e materiali idonei al contatto con gli alimenti
- Gas R452A
- Condensazione (A) aria
- Versioni Compact e Split*
- Voltaggi speciali, su richiesta
- Comandi "ON-OFF" a bordo macchina
- Macchine rispondenti alle normative di igiene e di sicurezza in vigore
- **Condizioni di lavoro standard:** temperatura acqua 15°C temperatura ambiente 20°C
- Sensore "troppo pieno" integrato



- Construction in stainless steel and specific materials approved for contact with food stuff
- Gas R452A
- (A) Air condensing
- Compact and Split* versions
- Special voltages, on request
- "ON-OFF" controls on board the machine
- Machines comply with hygiene and safety regulations
- **Standard working conditions:** incoming water temperature 15°C environment air temperature 20°C
- Built-in "overflow" sensor



- Construction en acier inox et matériaux pour aliments
- Gaz R452A
- Condensation (A) air
- Versions Compact et Split*
- Tensions spéciales, sur demande
- Commandes "ON-OFF" sur la machine
- Machines conformes aux normes en vigueur en matière d'hygiène et de sécurité
- **Conditions de travail standard:** température eau 15°C température environnement 20°C
- Capteur "trop plein" intégré



- Estructura de acero inoxidable y materiales para alimentos
- GAS R452A
- Condensación (A) aire
- Versiones Compact y Split*
- Voltajes especiales a petición
- Mandos ON/OFF instalados en la máquina
- Máquinas conformes a las normas vigentes en materia de higiene y seguridad
- **Condiciones de trabajo standards:** temperatura entrada agua: 15°C temperatura ambiente: 20°C
- Sensor "llenado" integrado

	GIM 1500N	GIM 1500NE Split*
Produzione - Productivity - Production - Producción	1500 kg/24 h	1500 kg/24 h
Temperatura ghiaccio - Ice temperature Température de la glace - Temperatura del hielo	0°C	0°C
Potenza frigorifera richiesta - Refrigerating capacity required Capacité frigorifique nécessaire - Capacidad frigorífica necesaria	-	9,8 kW (EN 12900-18°C +45°C)
Potenza elettrica - Electrical Power Puissance électrique - Potencia eléctrica	6 kW	0,80 kW
Peso netto - Net weight - Poids net - Peso neto	256 kg	190 kg
Tensione nominale - Volt Rated Tension nominale - Tensión nominal	V400/3/50Hz	V230/1/50Hz

ACCESSORI - ACCESSORIES - ACCESSOIRES - ACCESORIOS (pag. 30-33)



* Valvola KVP esclusa (optional) - KVP valve not included (optional) - Valve KVP exclue (en option) - Válvula KVP no incluida (opcional)





Ghiaccio in scaglie

Sottoraffreddato fino a -7°C è tipicamente con un grado di umidità inferiore al 7%, con grande superficie di contatto.

Il colore è bianco, pulito, ha una capacità di raffreddamento rapido degli alimenti ed è particolarmente drenante.

Consigliato per applicazioni in:

- Banchi pescheria (dettaglio o supermercati)
- Trasporto di derrate alimentari
- Processi industriali (panificazione, lavorazione carni, ecc.)
- Ristorazione collettiva
- Settore sanitario

Per la produzione di ghiaccio in scaglie l'evaporatore è costituito da un cilindro verticale fisso, sulla cui superficie l'acqua si ghiaccia istantaneamente. Lo strato di ghiaccio viene, poi, rimosso da un raschiatore.



FLAKE/SCALE ICE

Flake/scale ice

Chilled to -7°C , its humidity level is typically below 7%, with a large contact surface.

White, pure, dry texture, fast performing food cooling capacity and easy drainage.

Application fields varying from:

- Fishmongers' counter supermarkets,
- Perishable food transportation
- Industrial process
- Catering (bread making, meat processing, cooked meat trades ...)
- To pharmaceutical products handling.

For scale ice production, the evaporator is made up of a fixed vertical cylinder, on whose surface the water freezes instantaneously. The layer of ice is then removed by a scraper.



Glace en écaille

Sous-refroidie jusqu'à -7°C elle a typiquement un degré d'humidité inférieur à 7%, avec une grande surface de contact.

Blanche, pure, excellente capacité frigorifique pour un refroidissement rapide des aliments et une grande facilité de drainage.

Nombreuses applications:

- Etals de poissonneries au détail et supermarchés
- Transport de denrées périssables,
- Processus industriels
- Restauration collective (panification, transformation viande, plats cuisinés...)
- Produits pharmaceutiques

Pour la production de glace en écailles, l'évaporateur est constitué d'un cylindre vertical fixe, sur la surface duquel l'eau se glace instantanément. La couche de glace est ensuite enlevée par un racloir.

Hielo en escama

Enfriado a -7°C , presenta un grado de humedad inferior al 7 %, con una gran superficie de contacto.

El color es blanco, puro, teniendo una gran capacidad de enfriamiento rápido de los alimentos y es especialmente drenante.

Se utiliza para:

- Presentación de productos sobre los bancos con vista la público (pescaderías venta al detalle en supermercados)
- Transporte de alimentos
- Procesos industriales (panificación, elaboración de carnes, bloqueo en los procesos de cocción, etc.)
- Gastronomía en grandes escalas
- Sector sanitario

El evaporador, núcleo de la producción, está constituido por un cilindro vertical hueco donde se evapora el gas de refrigeración R404a que congela por contacto el agua que se derrama externamente al cilindro. La "capa" de hielo formada se resquebraja con un rascador que gira alrededor del cilindro.



FIM 250 - FIM 400

PRODUTTORI GHIACCIO IN SCAGLIE - FLAKE/SCALE ICE MAKERS
MACHINES À GLACE EN ÉCAILLES - FABRICADORES HIELO EN ESCAMAS



250-400 kg/24 h

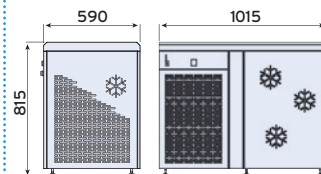

FIM 250

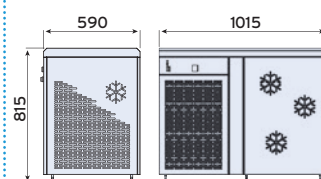

FIM 400



- Costruzione in acciaio inox e materiali idonei al contatto con gli alimenti***
- Gas R452A
- Condensazione (A) aria
- Voltaggi speciali, su richiesta
- Comandi "ON-OFF" a bordo macchina
- Macchine rispondenti alle normative di igiene e di sicurezza in vigore
- **Condizioni di lavoro standard:**
temperatura acqua 15°C
temperatura ambiente 20°C
- Cilindro evaporatore fisso verticale ad elevato scambio termico



- Construction in stainless steel and specific materials approved for contact with food stuff***
- Gas R452A
- (A) Air condensing
- Special voltages, on request
- "ON-OFF" controls on board the machine
- Machines comply with hygiene and safety regulations
- **Standard working conditions:**
incoming water temperature 15°C
environment air temperature 20°C
- Fixed vertical evaporator cylinder with high thermal exchange



- Construction en acier inox et matériaux pour aliments***
- Gaz R452A
- Condensation (A) air
- Tensions spéciales, sur demande
- Commandes "ON-OFF" sur la machine
- Machines conformes aux normes en vigueur en matière d'hygiène et de sécurité
- **Conditions de travail standard:**
température eau 15°C
température environnement 20°C
- Cylindre évaporateur fixe vertical à échange thermique élevé



- Estructura de acero inoxidable y materiales para alimentos***
- GAS R452A
- Condensación (A) aire
- Voltajes especiales a petición
- Mandos ON/OFF instalados en la máquina
- Máquinas conformes a las normas vigentes en materia de higiene y seguridad
- **Condiciones de trabajo standards:**
temperatura entrada agua: 15°C
temperatura ambiente: 20°C
- Cilindro evaporador vertical fijo con alto intercambio térmico

	FIM 250	FIM 400
Produzione - Productivity - Production - Producción	250 kg/24 h	400 kg/24 h
Temperatura ghiaccio - Ice temperature - Température de la glace - Temperatura del hielo	-5°C / -7°C	-5°C / -7°C
Spessore scaglia - Flake/scale thickness - Épaisseur écailles - Espesor escama**	0,9/1,2 mm	0,9/1,2 mm
Potenza elettrica - Electrical Power - Puissance électrique - Potencia eléctrica	1,09 kW	1,78 kW
Peso netto - Net weight - Poids net - Peso neto	170 kg	175 kg
Tensione nominale - Volt Rated - Tension nominale - Tensión nominal	V230/1/50Hz	V230/1/50Hz

ACCESSORI - ACCESSORIES - ACCESSOIRES - ACCESORIOS (pag. 30-33)



È fortemente raccomandata l'installazione del sensore (per il controllo del livello del ghiaccio) per un corretto e sicuro funzionamento dei flake ice makers (FIM series). Si prega di consultare pagina 31.
High recommended to install the sensor (electric barrier for ice level detection) for a correct and safety running of flake ice makers (FIM series). Please see pag. 31.
Il est fortement recommandé d'installer du capteur (pour la détection du niveau de la glace) pour le bon fonctionnement des Flake Ice Makers (FIM series). Veuillez voir la page 31.
Se recomienda la instalación del sensor nivel hielo para un correcto y seguro funcionamiento de la máquina escama (serie FIM). Favor ver pag. 31.

* Valvola KVP esclusa (optional) - KVP valve not included (optional) - Valve KVP exclue (en option) - Válvula KVP no incluida (opcional)

** Lo spessore potrà aumentare con l'aggiunta del dispositivo "salamoia" (opzionale) - The thickness can be increased assembling a salt feeding "brine" pump (optional) - L'épaisseur peut être augmentée par le montage d'une pompe d'alimentation de sel "saumure" (en option) - El espesor podrá aumentarse montando el dispositivo "salmuera" (opcional)

*** Versione senza rivestimento da confermare - Naked version to be confirmed - Version sans carter externe à confirmer - Versión sin carcasa externa a confirmar

600-950 kg/24 h



Vers. Compact

Vers. Split

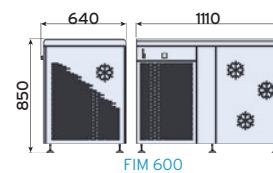

FIM 600

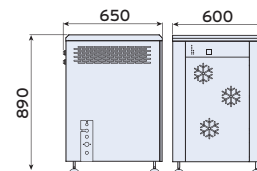

FIM 600E Split

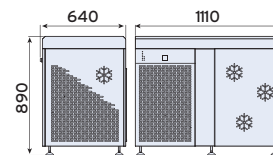

FIM 950

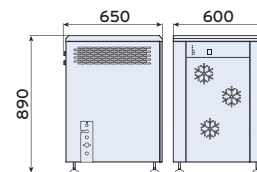

FIM 950E Split



- Costruzione in acciaio inox e materiali idonei al contatto con gli alimenti***
- Gas R452A
- Condensazione (A) aria
- Versioni Compact e Split*
- Voltaggi speciali, su richiesta
- Comandi "ON-OFF" a bordo macchina
- Macchine rispondenti alle normative di igiene e di sicurezza in vigore
- **Condizioni di lavoro standard:**
temperatura acqua 15°C
temperatura ambiente 20°C
- Cilindro evaporatore fisso verticale ad elevato scambio termico



- *Construction in stainless steel and specific materials approved for contact with food stuff****
- *Gas R452A*
- *(A) Air condensing*
- *Compact and Split* versions*
- *Special voltages, on request*
- *"ON-OFF" controls on board the machine*
- *Machines comply with hygiene and safety regulations*
- **Standard working conditions:**
incoming water temperature 15°C
environment air temperature 20°C
- *Fixed vertical evaporator cylinder with high thermal exchange*



- Construction en acier inox et matériaux pour aliments***
- Gaz R452A
- Condensation (A) air
- Versions Compact et Split*
- Tensions spéciales, sur demande
- Commandes "ON-OFF" sur la machine
- Machines conformes aux normes en vigueur en matière d'hygiène et de sécurité
- **Conditions de travail standard:**
température eau 15°C
température environnement 20°C
- *Cylindre évaporateur fixe vertical à échange thermique élevé*



- *Estructura de acero inoxidable y materiales para alimentos****
- *GAS R452A*
- *Condensación (A) aire*
- *Versiones Compact y Split**
- *Voltajes especiales a petición*
- *Mandos ON/OFF instalados en la máquina*
- *Máquinas conformes a las normas vigentes en materia de higiene y seguridad*
- **Condiciones de trabajo standards:**
temperatura entrada agua: 15°C
temperatura ambiente: 20°C
- *Cilindro evaporador vertical fijo con alto intercambio térmico*

	FIM 600	FIM 600E Split*	FIM 950	FIM 950E Split*
Produzione - Productivity - Production - Producción	600 kg/24 h	600 kg/24 h	950 kg/24 h	950 kg/24 h
Temperatura ghiaccio - Ice temperature - Température de la glace - Temperatura del hielo	-5°C / -7°C	-5°C / -7°C	-5°C / -7°C	-5°C / -7°C
Spessore scaglia - Flake/scale thickness - Épaisseur écailles - Espesor escama**	0,9/1,2 mm	0,9/1,2 mm	0,9/1,2 mm	0,9/1,2 mm
Potenza frigorifera richiesta - Refrigerating capacity required	-	2,41 kW	-	4,89 kW
Capacità frigorifera necessaria - Capacidad frigorífica necesaria	-	(EN 12900 -20°C +45°C)	-	(EN 12900 -20°C +45°C)
Potenza elettrica - Electrical Power - Puissance électrique - Potencia eléctrica	2,5 kW	0,58 kW	4,30 kW	0,58 kW
Peso netto - Net weight - Poids net - Peso neto	205 kg	115 kg	231 kg	135 kg
Tensione nominale - Volt Rated - Tension nominale - Tensión nominal	V400/3/50Hz	V230/1/50Hz	V400/3/50Hz	V230/1/50Hz

ACCESSORI - ACCESSORIES - ACCESSOIRES - ACCESORIOS (pag. 30-33)



È fortemente raccomandata l'installazione del sensore (per il controllo del livello del ghiaccio) per un corretto e sicuro funzionamento dei flake ice makers (FIM series). Si prega di consultare pagina 31.
High recommended to install the sensor (electric barrier for ice level detection) for a correct and safety running of flake ice makers (FIM series). Please see pag. 31.
Il est fortement recommandé d'installer du capteur (pour la détection du niveau de la glace) pour le bon fonctionnement des Flake Ice Makers (FIM series). Veuillez voir la page 31.
Se recomienda la instalación del sensor nivel hielo para un correcto y seguro funcionamiento de la máquina escama (serie FIM). Favor ver pag. 31.

* Valvola KVP esclusa (optional) - KVP valve not included (optional) - Valve KVP exclue (en option) - Válvula KVP no incluida (opcional)

** Lo spessore potrà aumentare con l'aggiunta del dispositivo "salamoia" (opzionale) - The thickness can be increased assembling a salt feeding "brine" pump (optional) - L'épaisseur peut être augmentée par le montage d'une pompe d'alimentation de sel "saumure" (en option) - El espesor podrá aumentarse montando el dispositivo "salmuera" (opcional)





*** Versione senza rivestimento da confermare - Naked version to be confirmed - Version sans carter externe à confirmer - Versión sin carcasa externa a confirmar

FIM 1500 - FIM 1500E SPLIT - FIM 3000
 PRODUTTORI GHIACCIO IN SCAGLIE - FLAKE/SCALE ICE MAKERS
 MACHINES À GLACE EN ÉCAILLES - FABRICADORES HIELO EN ESCAMAS

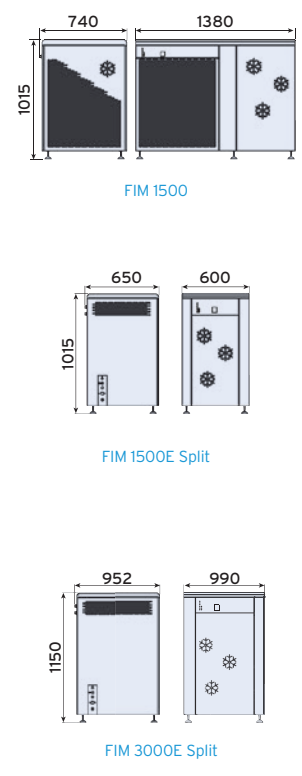

1500/3000 kg/24 h



- | | | | |
|--|--|---|---|
|  <ul style="list-style-type: none"> Costruzione in acciaio inox e materiali idonei al contatto con gli alimenti*** Gas R452A Condensazione (A) aria Versioni Compact e Split* Voltaggi speciali, su richiesta Macchine rispondenti alle normative di igiene e di sicurezza in vigore Condizioni di lavoro standard: temperatura acqua 15°C temperatura ambiente 20°C Cilindro evaporatore fisso verticale ad elevato scambio termico Pannello LCD completo per comando macchina (solo FIM 3000 split) Comandi ON-OFF a bordo macchina (solo FIM 1500) |  <ul style="list-style-type: none"> Construction in stainless steel and specific materials approved for contact with food stuff*** Gas R452A (A) Air condensing Compact and Split* versions Special voltages, on request Machines comply with hygiene and safety regulations Standard working conditions: incoming water temperature 15°C environment air temperature 20°C Fixed vertical evaporator cylinder with high thermal exchange Complete LCD panel for machine control (FIM 3000 split only) ON-OFF controls on board the machine (FIM 1500 only) |  <ul style="list-style-type: none"> Construction en acier inox et matériaux pour aliments*** Gaz R452A Condensation (A) aire Versions Compact et Split* Tensions spéciales, sur demande Machines conformes aux normes en vigueur en matière d'hygiène et de sécurité Conditions de travail standard: température eau 15°C température environnement 20°C Cylindre évaporateur fixe vertical à échange thermique élevé Ecran LCD de commande de la machine (FIM 3000 split seulement) Commandes ON-OFF sur la machine (FIM 1500 seulement) |  <ul style="list-style-type: none"> Estructura de acero inoxidable y materiales para alimentos*** GAS R452A Condensación (A) aire Versiones Compact y Split* Voltajes especiales a petición Máquinas conformes a las normas vigentes en materia de higiene y seguridad Condiciones de trabajo standards: temperatura entrada agua: 15°C temperatura ambiente: 20°C Cilindro evaporador vertical fijo con alto intercambio térmico Panel LCD completo para el mando de la máquina (solo FIM 3000 split) Mandos ON/OFF instalados en la máquina (solo FIM 1500) |
|--|--|---|---|

	FIM 1500	FIM 1500E Split*	FIM 3000E Split*
Produzione - Productivity - Production - Producción	1.500 kg/24 h	1.500 kg/24 h	3.000 kg/24 h
Temperatura ghiaccio - Ice temperature - Température de la glace - Temperatura del hielo	-5°C / -7°C	-5°C / -7°C	-5°C / -7°C
Spessore scaglia - Flake/scale thickness - Épaisseur écailles - Espesor escama**	0,9/1,2 mm	0,9/1,2 mm	0,9/1,2 mm
Potenza frigorifera richiesta - Refrigerating capacity required	-	6,54 kW	20,1 kW
Capacità frigorifera necessaria - Capacidad frigorífica necesaria	-	(EN 12900 -20°C +45°C)	(EN 12900 -20°C +45°C)
Potenza elettrica - Electrical Power - Puissance électrique - Potencia eléctrica	6 kW	0,58 kW	0,61 kW
Peso netto - Net weight - Poids net - Peso neto	381 kg	235 kg	295 kg
Tensione nominale - Volt Rated - Tension nominale - Tensión nominal	V400/3/50Hz	V230/1/50Hz	V230/1/50Hz

ACCESSORI - ACCESSORIES - ACCESSOIRES - ACCESORIOS (pag. 30-33)



È fortemente raccomandata l'installazione del sensore (per il controllo del livello del ghiaccio) per un corretto e sicuro funzionamento dei flake ice makers (FIM series). Si prega di consultare pagina 31.
 High recommended to install the sensor (electric barrier for ice level detection) for a correct and safety running of flake ice makers (FIM series). Please see pag. 31.
 Il est fortement recommandé d'installer du capteur (pour la détection du niveau de la glace) pour le bon fonctionnement des Flake Ice Makers (FIM series). Veuillez voir la page 31.
 Se recomienda la instalación del sensor nivel hielo para un correcto y seguro funcionamiento de la máquina escama (serie FIM). Favor ver pag. 31.

* Valvola KVP esclusa (optional) - KVP valve not included (optional) - Valve KVP exclue (en option) - Válvula KVP no incluida (opcional)
 ** Lo spessore potrà aumentare con l'aggiunta del dispositivo "salamoia" (opzionale) - The thickness can be increased assembling a salt feeding "brine" pump (optional) - L'épaisseur peut être augmentée par le montage d'une pompe d'alimentation de sel "saumure" (en option) - El espesor podrá aumentarse montando el dispositivo "salmuera" (opcional)
 *** Versione senza rivestimento da confermare - Naked version to be confirmed - Version sans carter externe à confirmer - Versión sin carcasa externa a confirmar

Ghiaccio in scaglie

Produrre ghiaccio direttamente a bordo delle barche da pesca? Con la serie FIM NE in versione Split, adatta alla produzione di ghiaccio in scaglie con acqua dolce o di mare, da oggi è possibile. Una soluzione tecnica disponibile per alte produzioni di ghiaccio in scaglie di spessore doppio rispetto alle macchine tradizionali. Misure contenute per adattarsi ai piccoli spazi, un ghiaccio sottoraffreddato fino a -14/-18°C grazie ad un cilindro evaporatore di tipo orizzontale con sistema di formazione a doppio giro per scaglie ancora più spesse e di lunga durata.

- Costruzione in acciaio Inox e materiali idonei per alimenti
- Solo versione Split
- Conformità alle norme di igiene e sicurezza in vigore
- Spessore scaglie fino a 2,5 - 3 mm
- Modelli per produzioni da 1200 Kg/24h a 8000 Kg/24h

Flake/scale ice

Produce ice directly onboard the fishing vessel? This is now possible with the Split version from the FIM NE series, designed to make ice flakes with fresh or sea water. A technical solution available for high-volume production of ice flakes twice the thickness of traditional machines. Compact size to adapt to small spaces, ice subcooled up to -14/-18°C thanks to a horizontal evaporator cylinder with dual-rotation forming system for thicker, longer-lasting flakes.

- Food-safe stainless steel construction and materials
- Split version only
- Complies with current hygiene and safety standards
- Flakes up to 2.5 - 3 mm thick
- Models for output from 1200 Kg/24h to 8000 Kg/24h

Glace en écaille

Produire de la glace directement à bord des bateaux de pêche? Avec la série FIM NE en version Split, adaptée à la production de glace en écailles avec de l'eau douce ou de l'eau de mer, cela est désormais possible ! Une solution technique disponible pour une production élevée de glace en écailles deux fois plus épaisses que les machines traditionnelles. Une taille compacte pour s'adapter aux petits espaces, glace sous-refroidie jusqu'à -14/-18°C grâce à un cylindre évaporateur horizontal avec un système de formation à double tour pour des écailles encore plus épaisses et plus durables.

- Construction en acier inoxydable et matériaux de qualité alimentaire
- Version Split uniquement
- Conforme aux normes d'hygiène et de sécurité en vigueur
- Epaisseur des écailles jusqu'à 2,5 - 3 mm
- Modèles pour des productions de 1 200 Kg/24h à 8 000 Kg/24h

Hielo en escama

¿Producir hielo directamente a bordo de los barcos de pesca? Con la serie FIM NE en versión Split, apta para la producción de hielo en escamas con agua dulce o marina, ahora es posible. Una solución técnica disponible para elevadas producciones de hielo en escamas de espesor doble con respecto a las máquinas tradicionales. Dimensiones reducidas para adaptarse a los pequeños espacios, un hielo subenfriado hasta -14/-18 °C gracias a un cilindro evaporador horizontal con sistema de formación de doble vuelta, que permite obtener escamas aún más gruesas y duraderas.

- Construcción de acero inoxidable y materiales idóneos para alimentos
- Solo versión Split
- Conforme a las normas de higiene y seguridad vigentes
- Espesor de las escamas hasta 2,5 - 3 mm
- Modelos para producciones de 1200 kg/24 h a 8000 kg/24 h



FLAKE/SCALE ICE

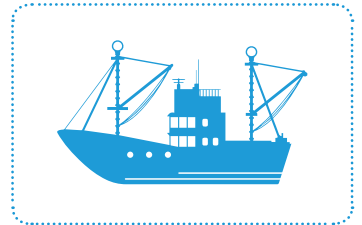

FIM 1200 NE SPLIT - FIM 2800 NE SPLIT - FIM 4000 NE SPLIT - FIM 5600 NE SPLIT - FIM 8000 NE SPLIT



PRODUTTORI GHIACCIO IN SCAGLIE - FLAKE/SCALE ICE MAKERS
MACHINES À GLACE EN ÉCAILLES - FABRICADORES HIELO EN ESCAMAS



1200/2800/4000/5600/8000 kg/24 h



- Adatta all'utilizzo con acqua dolce/salata e all'installazione "on board"
- Suitable for use with fresh/salt water and for "on board" installation
- Appropriée pour être utilisée avec eau fraîche/salée et l'installation "on board"
- Apta para agua dulce y salada y apta para la instalación "on board"

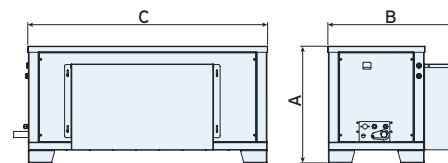

FIM 1200 NE Split - FIM 2800 NE Split - FIM 4000 NE Split
FIM 5600 NE Split - FIM 8000 NE Split

		FIM 1200 NE Split	FIM 2800 NE Split	FIM 4000 NE Split
A	mm	670	670	730
B	mm	721	721	846
C	mm	980	1370	1382



- Costruzione in acciaio inox ASI 316 e materiali idonei al contatto con gli alimenti
- Gas R452A
- Condensazione (A) aria
- **Solo versione Split***
- Voltaggi speciali, su richiesta
- Macchine rispondenti alle normative di igiene e di sicurezza in vigore
- **Condizioni di lavoro standard:**
temperatura acqua 15°C
temperatura ambiente 20°C
- Cilindro evaporatore orizzontale con sistema di formazione ghiaccio a doppio giro (per una scaglia più spessa)
- Coltello calettato su 5 parti estremamente resistente
- Adatta all'utilizzo con acqua dolce/salata e all'installazione "on board"



- Construction in stainless steel ASI 316 and specific materials approved for contact with food stuff
- Gas R452A
- (A) Air condensing
- **Only Split* version**
- Special voltages, on request
- Machines comply with hygiene and safety regulations
- **Standard working conditions:**
incoming water temperature 15°C
environment air temperature 20°C
- Horizontal evaporator cylinder with dual-rotation ice forming system (for a thicker flake)
- Extremely tough blade keyed on 5 parts
- Suitable for use with fresh/salt water and for "on board" installation



- Construction en acier inox ASI 316 et matériaux pour aliments
- Gaz R452A
- Condensation (A) air
- **Seulement version Split***
- Tensions spéciales, sur demande
- Machines conformes aux normes en vigueur en matière d'hygiène et de sécurité
- **Conditions de travail standard:**
température eau 15°C
température environnement 20°C
- Cylindre évaporateur horizontal avec système de formation de la glace à double tour (pour un copeau plus épais)
- Couteau emboîté sur 5 parties, extrêmement résistant
- Appropriée pour être utilisée avec eau fraîche/salée et l'installation "on board"



- Estructura de acero inoxidable ASI 316 y materiales para alimentos
- GAS R452A
- Condensación (A) aire
- **Solo versión Split***
- Voltajes especiales a petición
- Máquinas conformes a las normas vigentes en materia de higiene y seguridad
- **Condiciones de trabajo standards:**
temperatura entrada agua: 15°C
temperatura ambiente: 20°C
- Cilindro evaporador horizontal con sistema de formación hielo de doble vuelta (para obtener escamas más gruesas)
- Cuchilla ensamblada en 5 partes, extremadamente resistente
- Apta para agua dulce y salada y apta para la instalación "on board"

	FIM 1200 NE Split	FIM 2800 NE Split	FIM 4000 NE Split	FIM 5600 NE Split	FIM 8000 NE Split
Produzione/Productivity Production/Producción	1200 kg/24 h	2800 kg/24 h	4000 kg/24 h	5600 kg/24 h	8000 kg/24 h
Temperatura ghiaccio/Ice temperature / Température de la glace Temperatura del hielo	-14/-18	-14/-18	-14/-18	-14/-18	-14/-18
Spessore scaglia/Flake/scale thickness/Épaisseur écailles Espesor escama	2,5/3	2,5/3	2,5/3	2,5/3	2,5/3
Potenza frigorifera richiesta / Refrigerating capacity required Capacité frigorifique nécessaire /Capacidad frigorífica necesaria	7,4	16,5	19,5	28	35
Potenza elettrica/Electrical Power Puissance électrique/Potencia eléctrica	0,11	0,11	0,12	0,22	0,24
Peso netto/Net weight Poids net/Peso neto	135	180	290	350	520
Tensione nominale/Volt Rated Tension nominal/Tensión nominal	400 /3/ 50	400 /3/ 50	400 /3/ 50	400 /3/ 50	400 /3/ 50

* Valvola KVP esclusa (optional) - KVP valve not included (optional) - Valve KVP exclue (en option) - Válvula KVP no incluida (opcional)

Unità motocondensante non inclusa - Moto-Condensing Unit not included - Unité de condensation Non Inclus - Unidad Moto-Condensante No Incluida



Modello / Model Modèle / Modelo	Caratteristiche / Features Caractéristiques / Especificaciones	Split "E"	Dimensioni Dimensions Dimensions LxPxH (mm)	Peso Netto Net weight Poids net Peso neto (kg)	Potenza Assorbita / Power input / Puissance absorbée / Potencia absorbida (kW)	Potenza Frigorifera / Cooling capacity/ Puissance réfrigérante / Capacidad frigorífica (kW)	Corrente Assorbita / Current consumption / Courant absorbé / Corriente absorbida / (A)	Tensione nominale / Volt Rated / Tension nominale / Tensión nominal (V./Hz)
Gruppo/group/ groupe/grupo "PICCOLO"	 <p>Unità Motocondensante Carenata e silenziosa</p> <ul style="list-style-type: none"> • Raffreddamento ad aria • Equipaggiata con Pressostato - regolatore pressostatico ventola condensatore <p><i>Moto-condensing unit</i></p> <ul style="list-style-type: none"> • Streamlined and low noise level • Air-cooled <p>• Equipped with Pressure - switch for controlling the evaporator fan</p> <p>Unités de condensation</p> <ul style="list-style-type: none"> • Carénée et insonorisée • Refroidissement à air • Equipée avec Pressostat - pour contrôler le ventilateur sur l'évaporateur <p><i>Unidad moto-condensante</i></p> <ul style="list-style-type: none"> • Carenada y silenciada • Refrigerado por aire • Equipado con Presostato - para control ventilador del evaporador 	GIM 500N	1032 x 450 x 751	90	1,84	2,55	3,3	230/1/50
Gruppo/group/ groupe/grupo "MEDIO"		FIM 600 GIM 750N	1032 x 450 x 751	90	2,2	3,36	4,1	400/3/50
Gruppo/group/ groupe/grupo "GRANDE"		FIM 950 GIM 1000N	1182 x 450 x 901	120	4,95	6,88	11,6	400/3/50
Gruppo/group/ groupe/grupo "SUPER"		FIM 1500 GIM 1500N	1302 x 450 x 1201	200	9,5	11,6	18,5	400/3/50
Gruppo/group/ groupe/grupo "MEGA"		FIM 3000	1750 x 946 x 1497	456	11,38	18	24,2	400/3/50



	BH 180	BH 250	BH 400
Capacità - Capacity Capacité - Capacidad	180 kg	250 kg	400 kg
Dimensioni (LxPxH) Dimensions (LxWxH) Encombrement (LxWxH) Dimensiones (LxWxH)	768 x 848 x 1048 mm	1081 x 824 x 968 mm	1235 x 873 x 1270 mm



Contenitore coibentato per ghiaccio LIFO. Costruzione in acciaio inox, prelievo ghiaccio da sportello ad altezza uomo.



LIFO Ice storage bins. Stainless steel exterior, top and lift door. CFC free polyurethane foam insulation.



Cabine de stockage LIFO à face inclinée extérieur en acier inox. Le paroi et le revêtement intérieur sont collés à un isolant en mousse de polyuréthane sans CFC.



Almacenamiento tipo LIFO. Construido en acero inox (externo) con aislación interna de espuma de poliuretano (sin contenido CFC)



	BL 550	BL 810
Capacità - Capacity Capacité - Capacidad	550 kg	810 kg
Dimensioni (LxPxH) Dimensions (LxWxH) Encombrement (LxWxH) Dimensiones (LxWxH)	1220 x 1125 x 1428 mm (Max Profondità/ Max Depth 1410 mm)	1524 x 1125 x 1735 mm (Max Profondità/ Max Depth 1410 mm)

Contenitore coibentato per ghiaccio FIFO. Costruzione in acciaio inox, prelievo ghiaccio da sportello alla base.

FIFO (lower door) Ice storage bins. Stainless steel exterior and top. CFC free polyurethane foam insulation.

Cabine de stockage FIFO à face inclinée extérieur en acier inox. Le paroi extérieure et le revêtement intérieur sont collés à un isolant en mousse de polyuréthane sans CFC.

Almacenamiento tipo FIFO (compuerta inferior con puerta). Construido en acero inox (externo) con aislación interna de espuma de poliuretano (sin contenido CFC)



	BC 320	BC 610
Capacità - Capacity Capacité - Capacidad	320 kg	610 kg
Dimensioni (LxPxH) Dimensions (LxWxH) Encombrement (LxWxH) Dimensiones (LxWxH)	885 x 1267 x 1803 mm Max Profondità / Max Depth 2200	1753 x 1267 x 1803 mm Max Profondità / Max Depth 2200
Carrelli inclusi Trolley Cart included	1	2

Contenitore coibentato per ghiaccio LIFO. Costruzione in acciaio inox con saracinesca alla base per scarico su carrello.

LIFO (upper door) or FIFO (trolley) Ice storage bins. Stainless steel exterior and top. CFC free polyurethane foam insulation.

LIFO (upper door) or FIFO (trolley) Cabine de stockage en acier inox Le paroi extérieur et le revêtement intérieur sont collés à un isolant en mousse de polyuréthane sans CFC.

Almacenamiento tipo LIFO (ventana superior) o FIFO (carro). Construido en acero inox (externo) con aislación interna de espuma de poliuretano (sin contenido CFC)

ICE MAKER	BH 180	BH 250	BH 400	BL 550	BL 810	BC 320	BC 610
GIM 360N	•	•	•	•	•	•	•
GIM 500N	•	•	•	•	•	•	•
GIM 750N	•	-	•	•	•	•	•
GIM 1000N	-	-	-	•	•	•	•
GIM 1500N	-	-	-	•	•	•	•
GIM 500NE	•	•	•	•	•	•	•
GIM 750NE	•	-	•	•	•	•	•
GIM 1000NE	-	-	-	•	•	•	•
GIM 1500NE	-	-	-	•	•	•	•
FIM 250	-	-	•	•	•	•	•
FIM 400	-	-	•	•	•	•	•
FIM 600	-	-	•	•	•	•	•
FIM 950	-	-	•	•	•	•	•
FIM 1500	-	-	-	-	•	-	•
FIM 600E	-	-	•	•	•	•	•
FIM 950E	-	-	•	•	•	•	•
FIM 1500E	-	-	•	•	•	•	•



TROLLEY 300

- 300 litri (150 kg)
- Vasca non coibentata
- Materiale plastico con coperchio e montata su ruote
- Dimensione: 700 x 1000 x 750 h mm
- Non utilizzabile per Tavolo ICE1



TROLLEY 300

- 300 litres (150 kg)
- Non insulated
- Reinforced plastic trolley with lid and self-braking wheels
- Dimensions: 700 x 1000 x 750 h mm
- Not for use on ICE1 Table



TROLLEY 300

- 300 litres (150 kg)
- Non isolé
- Chariot en plastique renforcée sur roues avec couvercle
- Encombrement: 700 x 1000 x 750 h mm
- Non utilisable pour Table ICE1



TROLLEY 300

- 300 litros de capacidad (150 kg)
- Construido en plástico reforzado (no aislado), con tapa y ruedas autofrenantes
- Dimensiones: 700 x 1000 x 750 h mm
- No adecuado para Banco ICE1



TROLLEY CART 57R

- 119 litri (57 kg)
- Carrello coibentato in materiale plastico, montato su ruote con coperchio ribaltabile
- Dimensione: 572 x 718 x 851 h mm

TROLLEY CART 57R

- 119 litres (57 kg)
- Reinforced insulated poly trolley with lift-up lid
- 119 liters (57 kg)
- Dimensions: 572 x 718 x 851 h mm

TROLLEY CART 57R

- 119 litres (57 kg)
- Chariot en plastique renforcée sur roues avec couvercle basculant
- Non isolé
- Encombrement: 572 x 718 x 851 h mm

TROLLEY CART 57R

- 119 litros de capacidad (57 kg)
- Construido en plástico reforzado (aislado), con tapa apertura giratoria y ruedas autofrenantes
- Dimensiones: 572 x 718 x 851 h mm



TROLLEY CART 57S

- 119 litri (57 kg)
- Carrello coibentato in materiale plastico, montato su ruote con coperchio scorrevole
- Dimensione: 585 x 801 x 743 h mm

TROLLEY CART 57S

- 119 litres (57 kg)
- Reinforced insulated poly trolley with slide-back lid
- Dimensions: 585 x 801 x 743 h mm

TROLLEY CART 57S

- 119 litres (57 kg)
- Chariot en plastique renforcée sur roues avec couvercle glissant
- Non isolé
- Encombrement: 585 x 801 x 743 h mm

TROLLEY CART 57S

- 119 litros de capacidad (57 kg)
- Construido en plástico reforzado (aislado), con tapa apertura deslizable y ruedas autofrenantes
- Dimensiones: 585 x 801 x 743 h mm



TROLLEY CART 109

- 228 litri (109 kg)
- Carrello coibentato in materiale plastico, montato su ruote con coperchio rimovibile
- Dimensione: 616 x 1054 x 908 h mm

TROLLEY CART 109

- 228 litres (109 kg)
- Reinforced insulated poly trolley with removable lid
- Dimensions: 616 x 1054 x 908 h mm

TROLLEY CART 109

- 228 litres (109 kg)
- Chariot en plastique renforcée sur roues avec couvercle amovible
- Non isolé
- Encombrement: 616 x 1054 x 908 h mm

TROLLEY CART 109

- 228 litros de capacidad (109 kg)
- Construido en plástico reforzado (aislado), con tapa apertura desmontable
- Dimensiones: 616 x 1054 x 908 h mm



CONTENITORI

- Set nr. 6 contenitori per TROLLEY CART 109
- Capacità contenitore: 12 kg cad.

BUCKETS/PAILS

- Set of nr. 6 pails for TROLLEY CART 109
- Pail capacity: 12 kg ea

RÉCIPIENTS

- Kit 6 récipient plastique pour TROLLEY CART 109
- Capacité: 12 kg chacun

BALDES

- Set de nr. 6 baldes para carro CART 109
- Capacidad: 12 kg c/u



ASTA ROMPIGHIACCIO

- Materiale plastico alta densità

PADDLE

- High density ice breaker

FRAISE

- Fraise en plastique haute densité

ROMPE-HIELO

- Bastón para rotura hielo



PALA

- Pala in materiale plastico

SHOVEL

- Poly scoop

PELLE

- Plastique haute densité

PALA

- Pala de grandes dimensiones

PALETTA

- Paletta in materiale plastico ad alta densità

SCOOP

- Heavy duty poly construction

PELLE

- Dimension contenue plastique haute densité

PALITA

- Palita pequeña



SENSORE

- Sensore per controllo livello del ghiaccio con regolazione

SENSOR

- Electric barrier for ice level detection with adjustment

CAPTEUR

- Capteur pour detection niveau de glace avec réglage

SENSOR

- Sensor para control de nivel de hielo (con ajuste)

È fortemente raccomandata l'installazione del sensore (per il controllo del livello del ghiaccio) per un corretto e sicuro funzionamento dei flake ice makers (FIM series)
High recommended to install the sensor (electric barrier for ice level detection) for a correct and safety running of flake ice makers (FIM series).
Il est fortement recommandé d'installer du capteur (pour la détection du niveau de la glace) pour le bon fonctionnement des Flake Ice Makers (FIM series).
Se recomienda la instalacion del sensor nivel hielo para un correcto y seguro funcionamiento de la maquina escama (serie FIM).



**PER GIM-N
CONTROLLO REMOTO
ON-OFF**
Lunghezza cavo standard
10 m.
(non disponibile per GIM
100/15N - GIM 140/25N)



**FOR GIM-N
REMOTE ON/OFF SWITCH**
10 m standard connecting
cable.
(no available for GIM
100/15N - GIM 140/25N)



**POUR GIM-N
ACCÈS ON/OFF À
DISTANCE**
Longuer cable branchement
10 mt. (non disponible pour
GIM 100/15N - GIM 140/25N)



**PARA GIM-N
ON/OFF REMOTO**
Longitud cable standard
10 m
(no disponible para GIM
100/15N - GIM 140/25N)



**PER GIM-N
CONTROLLO
REMOTO CON TIMER
SETTIMANALE**
Lunghezza cavo standard
10 m.
(non disponibile per GIM
100/15N - GIM 140/25N)

**FOR GIM-N
REMOTE CONTROL WITH
WEEKLY TIMER**
10 m standard connecting
cable.
(no available for GIM
100/15N - GIM 140/25N)

**POUR GIM-N
TELECOMMANDE AVEC
MINUTERIE HEBDOMADAIRE**
Longuer cable branchement
10 mt
(non disponible pour
GIM 100/15N - GIM 140/25N)

**PARA GIM-N
COMANDOS REMOTOS
CON TIMER SEMANAL**
Longitud cable standard
10 m
(no disponible para GIM
100/15N - GIM 140/25N)



**PER FIM
CONTROLLO REMOTO
ON-OFF**
Lunghezza cavo standard
10 m.
(non ordinabile per il mod.
FIM 3000)

**FOR FIM
REMOTE ON/OFF SWITCH**
10 m standard connecting
cable.
(not available for the mod.
FIM 3000)

**POUR FIM
ACCÈS ON/OFF À
DISTANCE**
Longuer cable branchement
10 mt
(Pas disponible pour le mod.
FIM 3000).

**PARA FIM
ON/OFF REMOTO**
Longitud cable standard
10 m
(no disponible para el mod.
FIM 3000)



**Per FIM
CONTROLLO REMOTO
CON PANNELLO LCD E
TIMER SETTIMANALE**
Lunghezza cavo standard
10 m.
(di serie nel mod. FIM 3000)

**For FIM
REMOTE CONTROL WITH
LCD PANEL AND WEEKLY
TIMER**
10 m standard connecting cable.
(already supplied on the mod.
FIM 3000)

**POUR FIM
TELECOMMANDE A ECRAN
LCD ET MINUTERIE
HEBDOMADAIRE**
Longuer cable branchement
10 mt.
(de série dans le mod. FIM 3000)

**PARA FIM
CONTROL REMOTO CON
PANEL LCD Y TIMER
SEMANAL**
Longitud cable standard
10 m
(de serie en el mod. FIM 3000)



FILTRO INGRESSO H₂O
Filtro a cartuccia per
acqua 90 micron

H₂O INLET FILTER
Water supply cartridge
filter for impurities up to
90 micron

FILTRE INTRÉE H₂O
Filtre à impuretés de
dimension de 90
micron.

FILTRO INGRESO H₂O
Cartucho para impurezas
de 90 micrones



DOSATORE
Dosatore di sali polifosfati
per prevenire deposito di
calcare.

DISPENSER
Powder dosing unit of
polyphosphate salts to
prevent scale built-up/
limestone.

DOSEUR
Doseur sel polyphosphate
qui previenne dépôt
calcaire.

DOSIFICADOR
Dosificador de sales poli-
fosfatadas para prevenir
acumulación de calcio
("sarro").



SALI
Sali polifosfati per
prevenire deposito di
calcare.

SALTS
Polyphosphate salts
to prevent scale
built-up/limestone.

SELS
Sel polyphosphate qui
previenne dépôt
calcaire.

SAL
Sales polifosfatadas para
prevenir acumulación de
calcio ("sarro").



VALVOLA KVP

KVP 15
KVP 22
KVP 28

KVP VALVE

KVP 15
KVP 22
KVP 28

VALVE KVP

KVP 15
KVP 22
KVP 28

VÁLVULA KVP

KVP 15
KVP 22
KVP 28



SALAMOIA
Dosatore salamoia per
aumento spessore
scaglia (linea FIM)
(i tubi di collegamento ed
il serbatoio della salamoia
non sono inclusi)

BRINE
Brine dispenser for incre-
asing the flake thickness
(FIM series)
(joining tubes and brine
tank not included)

SAUMURE
Doseur saumure pour
augmenter l'épaisseur du
écailles (série FILM)
(Les tubes de raccord et le
réservoir de saumure ne
sont pas inclus.)

SALMUERA
Dosificador salmuera para
aumento espesor escama
(línea FIM)
(Las tuberías de conexión y
el reservorio de salmuera
no incluidos)





INVERTER/VELOCITÀ

Per aumento spessore scaglia (possibile decremento produttività)



INVERTER/SPEED

For increasing the flake thickness (possible decreasing of productivity)



INVERTER/VITESSE

Pour augmenter l'épaisseur du écailles (possibilité de diminution de la productivité)



INVERTER/VELOCIDAD

Para aumento espesor escama (posible disminución de la productividad)



TAVOLO

Cavalletto tubolare in acciaio inox.

TABLE

Stainless steel table.

TABLE

Etal en acier inox.

BANCO

Construido en acero inox.

Rif. ICE 1: 815x900x970h (esterno) / 710x900x890h (interno) - **GIM 360N - GIM 500N - GIM 750N - GIM 1000N - GIM 1500N**

Rif. ICE 2: 925x900x970h (esterno) / 820x900x890h (interno) - **GIM 1500N**

Rif. ICE 3: 1260x900x970h (esterno) / 1130x820x890h (interno) - **FIM 250 - FIM 400 - FIM 600 - FIM 950**

Rif. ICE 4: 1410x900x970h (esterno) / 1310x900x890h (interno) - **FIM 1500**



DISTRIBUTORE SINGOLO FIM, GIM-N

Dispositivo per distribuzione omogenea ghiaccio. Materiale inox fissato su base macchina. Materiale inox.

SINGLE DISTRIBUTOR FIM, GIM-N

Device for homogeneous ice distribution. Stainless steel material fixed to machine base. Stainless steel material.

DISTRIBUTEUR SIMPLE FIM, GIM-N

Dispositif de distribution homogène de la glace. Matériau inox fixé sur la base de la machine. Matériau inox.

DISTRIBUIDOR INDIVIDUAL FIM, GIM-N

Dispositivo para la distribución homogénea del hielo. Material inoxidable fijado en la base de la máquina. Material inoxidable.



DISTRIBUTORE DOPPIO GIM-N

Dispositivo per distribuzione omogenea ghiaccio. Materiale inox fissato su base macchina. Materiale inox.

DOUBLE DISTRIBUTOR GIM-N

Device for homogeneous ice distribution. Stainless steel material fixed to machine base. Stainless steel material.

DISTRIBUTEUR DOUBLE GIM-N

Dispositif de distribution homogène de la glace. Matériau inox fixé sur la base de la machine. Matériau inox.

DISTRIBUIDOR DOBLE GIM-N

Dispositivo para la distribución homogénea del hielo. Material inoxidable fijado en la base de la máquina. Material inoxidable.

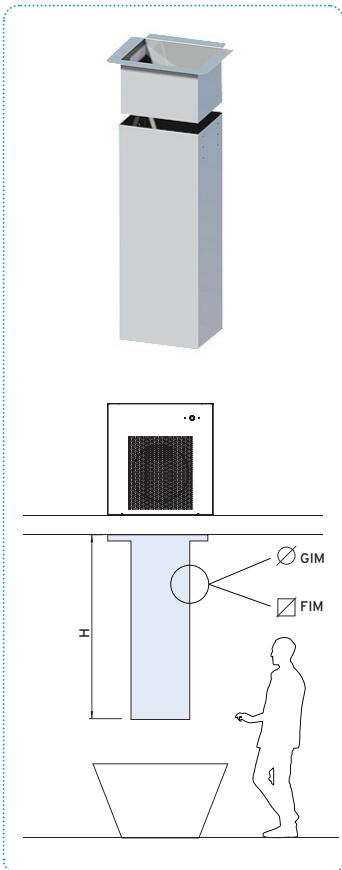

Convogliatori verticali in acciaio inox

Stainless steel modular ice chute

Goulottes modulaires vertical

Canales de descarga modulares construidos en acero inox

Per GIM-N KIT CANALE 500 G

• Dimensioni esterne: Ø 115 x 500 h mm

KIT CANALE 1000 G

• Dimensioni esterne: Ø 115 x 1000 h mm

KIT CANALE 2000 G

• Dimensioni esterne: Ø 115 x 2000 h mm

For GIM-N CHANNEL 500 G

• External dimensions: Ø 115 x 500 h mm

CHANNEL 1000 G

• External dimensions: Ø 115 x 1000 h mm

CHANNEL 2000 G

• External dimensions: Ø 115 x 2000 h mm

Pour GIM-N Chute 500 G

• Dimensions extérieures: Ø 115 x 500 h mm

Chute 1000 G

• Dimensions extérieures: Ø 115 x 1000 h mm

Chute 2000 G

• Dimensions extérieures: Ø 115 x 2000 h mm

Para GIM-N CANAL 500 G

• Dimensiones externas: Ø 115 x 500 h mm

CANAL 1000 G

• Dimensiones externas: Ø 115 x 1000 h mm

CANAL 2000 G

• Dimensiones externas: Ø 115 x 2000 h mm

Per FIM 250...1500 KIT CANALE 500 F

• Dimensioni esterne: 475 x 425 x 500 h mm

KIT CANALE 1000 F

• Dimensioni esterne: 475 x 425 x 1000 h mm

KIT CANALE 1500 F

• Dimensioni esterne: 475 x 425 x 1500 h mm

KIT CANALE 2000 F

• Dimensioni esterne: 475 x 425 x 2000 h mm

For FIM 250...1500 CHANNEL 500 F

• External dimensions: 475 x 425 x 500 h mm

CHANNEL 1000 F

• External dimensions: 475 x 425 x 1000 h mm

CHANNEL 1500 F

• External dimensions: 475 x 425 x 1500 h mm

CHANNEL 2000 F

• External dimensions: 475 x 425 x 2000 h mm

Pour FIM 250...1500 Chute 500 F

• Dimensions extérieures: 475 x 425 x 500 h mm

Chute 1000 F

• Dimensions extérieures: 475 x 425 x 1000 h mm

Chute 1500 F

• Dimensions extérieures: 475 x 425 x 1500 h mm

Chute 2000 F

• Dimensions extérieures: 475 x 425 x 2000 h mm

Para FIM 250...1500 CANAL 500 F

• Dimensiones externas: 475 x 425 x 500 h mm

CANAL 1000 F

• Dimensiones externas: 475 x 425 x 1000 h mm

CANAL 1500 F

• Dimensiones externas: 475 x 425 x 1500 h mm

CANAL 2000 F

• Dimensiones externas: 475 x 425 x 2000 h mm

Per FIM 3000 KIT CANALE 500 D

• Dimensioni esterne: 595 x 595 x 500 h mm

KIT CANALE 1000 D

• Dimensioni esterne: 595 x 595 x 1000 h mm

KIT CANALE 1500 D

• Dimensioni esterne: 595 x 595 x 1500 h mm

KIT CANALE 2000 D

• Dimensioni esterne: 595 x 595 x 2000 h mm

For FIM 3000 CHANNEL 500 D

• External dimensions: 595 x 595 x 500 h mm

CHANNEL 1000 D

• External dimensions: 595 x 595 x 1000 h mm

CHANNEL 1500 D

• External dimensions: 595 x 595 x 1500 h mm

CHANNEL 2000 D

• External dimensions: 595 x 595 x 2000 h mm

Pour FIM 3000 Chute 500 D

• Dimensions extérieures: 595 x 595 x 500 h mm

Chute 1000 D

• Dimensions extérieures: 595 x 595 x 1000 h mm

Chute 1500 D

• Dimensions extérieures: 595 x 595 x 1500 h mm

Chute 2000 D

• Dimensions extérieures: 595 x 595 x 2000 h mm

Para FIM 3000 CANAL 500 D

• Dimensiones externas: 595 x 595 x 500 h mm

CANAL 1000 D

• Dimensiones externas: 595 x 595 x 1000 h mm

CANAL 1500 D

• Dimensiones externas: 595 x 595 x 1500 h mm

CANAL 2000 D

• Dimensiones externas: 595 x 595 x 2000 h mm



NOTE _____

Lined area for writing notes, consisting of approximately 28 horizontal lines.



9656-A

l'istituto KIWA CERMET ha certificato il nostro SISTEMA di QUALITÀ AZIENDALE conforme alle norme
UNI EN ISO 9001:2015 per le tipologie di prodotti e servizi

“Progettazione, sviluppo, fabbricazione e commercializzazione di macchine per la lavorazione degli alimenti ed il loro confezionamento e conservazione”

La certificazione conferma il livello della qualità globale dell'Azienda e costituisce per noi una forte motivazione ad un continuo miglioramento, con particolare riferimento alla soddisfazione del cliente. Minerva Omega group s.r.l. ha sempre investito, nello sviluppo di nuovi prodotti, nel miglioramento del servizio, nelle risorse umane, nelle attrezzature di produzione, nel sistema informativo. Minerva Omega group s.r.l. è un'azienda che guarda al futuro, e il Sistema di Certificazione garantirà l'applicazione armonica delle strategie, fornendoci gli strumenti organizzativi più idonei.

*The certifying body KIWA CERMET has certified our COMPANY QUALITY SYSTEM to be in conformity with standard
UNI EN ISO 9001:2015 for the following types of products and services:*

“Design, development, manufacture and marketing of machines for food processing, packaging and preservation”

This certification testifies to the Company's level of global quality and represents for us a strong motivation toward continuous improvement, in particular on the customer satisfaction Minerva Omega group s.r.l. has always invested in the development of new products, improvement of service, human resources, manufacturing equipment and information systems.

Minerva Omega group s.r.l. is a company with its sights set on the future and the Certification System will provide us.



Ice-Tek®

Minerva Omega group s.r.l.
Via del Vetraio, 36 - 40138 Bologna - Italy
Tel. +39 051 530.174 - Fax +39 051 535.327
laminerva@laminerva.it - info@ice-tek.it



www.ice-tek.it
www.minervaomegagroup.com



Specifications and other features are subject to change without notice; the pictures must be considered as indicative and they can take a configuration/dimension from a similar machine.

